

NORA-B2 series (u-connectXpress)

Stand-alone Bluetooth® modules

Data sheet

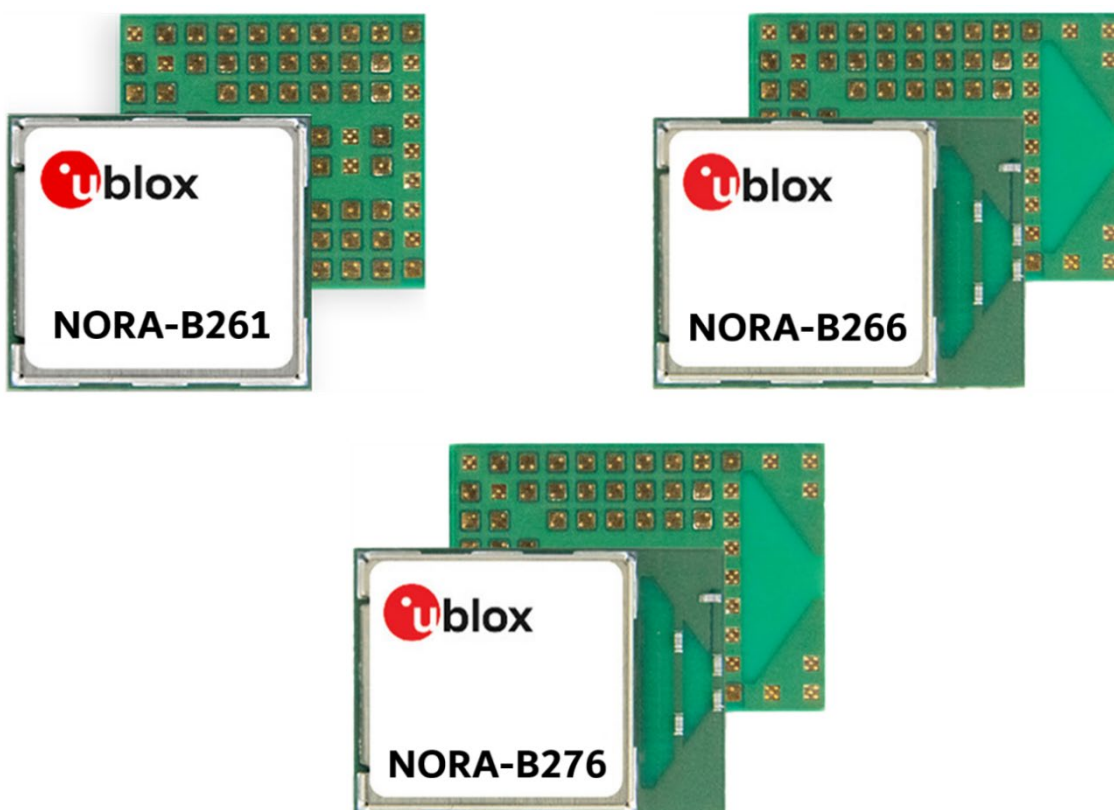

Abstract

Aimed towards developers and other technical staff, this document provides important information necessary for the design of customer applications based on the module. It includes an overview and comprehensive functional description of each NORA-B2 module variants – together with a detailed pin list, block diagram, mechanical and electrical specification, and more.

Document information

Title	NORA-B2 series (u-connectXpress)	
Subtitle	Stand-alone Bluetooth® modules	
Document type	Data sheet	
Document number	UBXDOC-465451970-4608	
Revision and date	R03	8-Dec-2025
Disclosure restriction	C1-Public	

Product status	Corresponding content status	
Functional sample	Draft	For functional testing. Revised and supplementary data will be published later.
In development / Prototype	Objective specification	Target values. Revised and supplementary data will be published later.
Engineering sample	Advance information	Data based on early testing. Revised and supplementary data will be published later.
Initial production	Early production information	Data from product verification. Revised and supplementary data may be published later.
Mass production / End of life	Production information	Document contains the final product specification.

This document applies to the following products:

Product name	Type number	Hardware version	PCN reference	Product Status
NORA-B261	NORA-B261-00B-00	01	N/A	Initial Production
NORA-B266	NORA-B266-00B-00	02	N/A	Initial Production
NORA-B276	NORA-B276-00B-00	02	N/A	Engineering Sample

u-blox or third parties may hold intellectual property rights in the products, names, logos, and designs included in this document. Copying, reproduction, or modification of this document or any part thereof is only permitted with the express written permission of u-blox. Disclosure to third parties is permitted for clearly public documents only.

The information contained herein is provided "as is" and u-blox assumes no liability for its use. No warranty, either express or implied, is given, including but not limited to, with respect to the accuracy, correctness, reliability, and fitness for a particular purpose of the information. This document may be revised by u-blox at any time without notice. For the most recent documents and statuses, visit www.u-blox.com.

Copyright © u-blox AG.

Contents

Document information	2
Contents	3
1 Functional description	5
1.1 Overview.....	5
1.2 Applications.....	5
1.3 Block diagram.....	6
1.4 Product variants.....	6
1.5 Radio performance.....	7
1.6 u-connectXpress software.....	7
1.6.1 AT command support.....	7
1.6.2 Software update.....	7
1.7 Power save modes.....	8
1.7.1 Wake-up sources.....	8
2 Interfaces	9
2.1 Power supply.....	9
2.2 Low frequency clock.....	9
2.3 Module reset.....	9
2.4 System control signals.....	9
2.5 RF antenna interfaces.....	9
2.5.1 Internal antenna.....	9
2.5.2 External RF antenna interface.....	9
2.6 Data interfaces.....	10
2.6.1 UART.....	10
3 Pin definition	11
3.1 Pin assignment.....	11
3.2 Pinout.....	11
4 Electrical specifications	14
4.1 Absolute maximum ratings.....	14
4.1.1 Maximum ESD ratings.....	14
4.1.2 Non-volatile memory endurance.....	14
4.2 Recommended operating conditions.....	15
4.2.1 Operating and storage temperature range.....	15
4.2.2 Supply/power pin.....	15
4.2.3 RESET_N pin.....	15
4.2.4 Digital pins.....	15
4.2.5 Current consumption.....	16
4.2.6 Throughput performance.....	16
4.2.7 RF performance.....	17
4.2.8 Antenna radiation patterns.....	17

5	Mechanical specifications	20
5.1	NORA-B2 footprint dimensions	20
5.2	NORA-B2 mechanical specification	22
5.2.1	NORA-B2x6 mechanical specifications	22
5.2.2	NORA-B2x1 mechanical specification	22
6	Qualifications and approvals	23
6.1	Country approvals	23
6.2	Bluetooth qualification	23
7	Product handling	24
7.1	Packaging	24
7.1.1	Reels	24
7.1.2	Tapes	24
7.2	Moisture sensitivity levels	26
7.3	Reflow soldering	26
7.4	ESD precautions	26
8	Labeling and ordering information	27
8.1	Module marking	27
8.2	Product identifiers	28
8.3	Identification codes	28
8.4	Ordering information	28
	Appendix	29
A	Glossary	29
	Related documents	31
	Revision history	31
	Contact	31

1 Functional description

1.1 Overview

Based on the Nordic Semiconductor nRF54L series Bluetooth® LE System on Chip (SoC), the NORA-B2 is a series of small stand-alone modules includes Arm® Cortex®-M33 processor, which provides a floating-point unit (FPU), digital signal processor (DSP) instruction set, and CryptoCell™-312 security architecture. It also features a 128 MHz RISC-V coprocessor. NORA-B2 modules are qualified against Bluetooth® Core 6.0.

Shipped with pre-flashed u-connectXpress software, NORA-B2 modules simplify end-product integration and reduce the time-to-market for end-user applications. The host controller configures and controls the wireless communication using high-level AT commands – without the need for expertise in Bluetooth protocols stacks.

NORA-B2 series operate at ambient temperatures range of -40 °C to 85 °C. The modules offer multiple antenna options, including antenna pin and on-board PCB trace antenna options. For more information about the antennas that are approved for use with the NORA-B2 series, see also the system integration manual [\[1\]](#).

1.2 Applications

NORA-B2 series modules provide scalable solutions for a broad range of market segments, including smart cities and buildings, industrial automation, telematics, medical, and healthcare.

Specific application areas include:

- Industrial automation
- Advanced wearables
- Smart buildings and cities
- Low-power sensors
- Wireless-connected and configurable equipment
- Point-of-sale
- Medical and health devices
- Real-time Location, RTLS
- Indoor positioning
- Asset tracking
- Access control

1.3 Block diagram

Figure 1 shows the integration of the nRF54Lxx and other logical components in NORA-B2 modules.

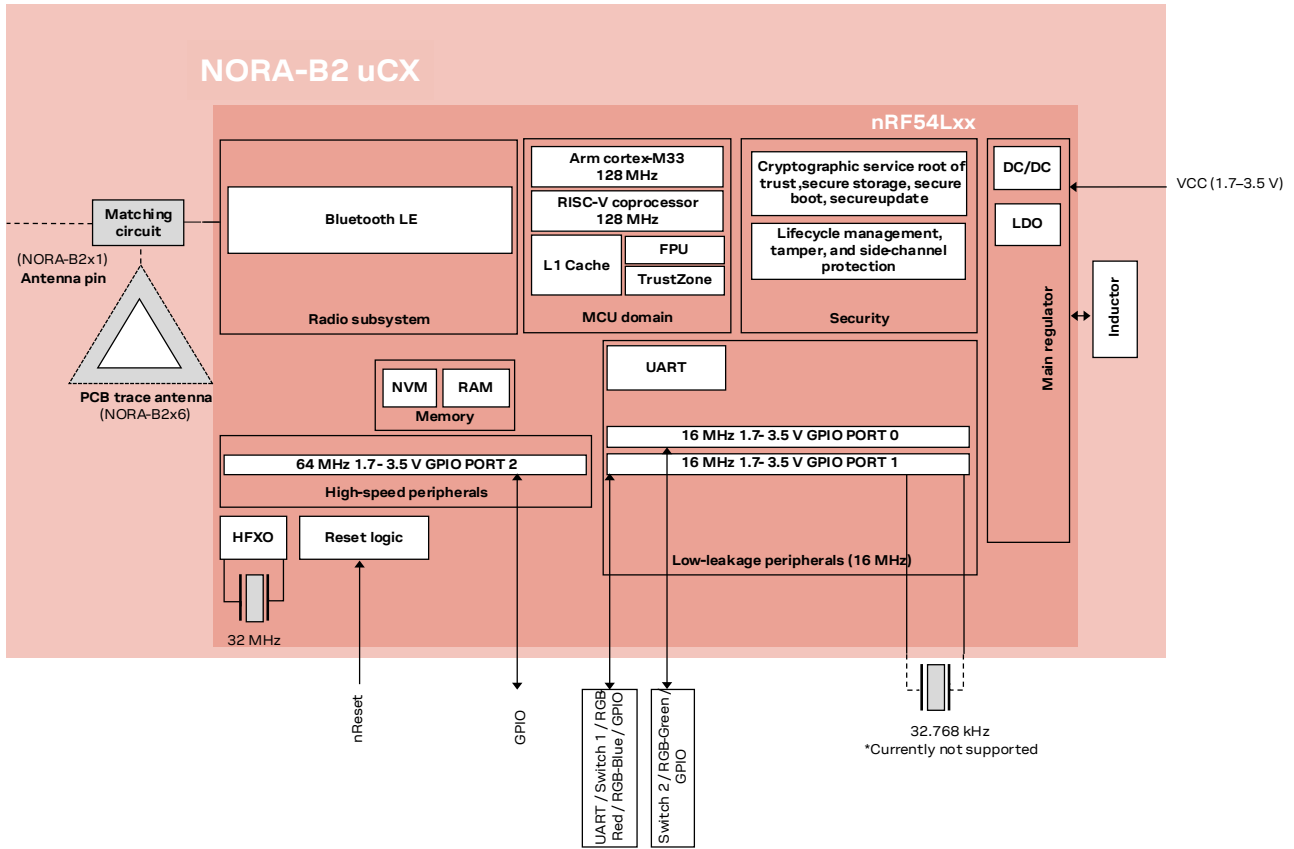

Figure 1: Block diagram of NORA-B2 series

1.4 Product variants

The NORA-B2 series modules come with two different antenna options. NORA-B2x1 supports an antenna pin for use with external antennas, while NORA-B2x6 includes an integrated PCB antenna. All product variants are professional grades.

Table 1 describes the main differences between the NORA-B2 various module variants.

Variants	CPU	Antenna	RAM	NVM	Weight [g]	Dimensions [mm]
NORA-B261	nRF54L10	Pin	192 kB	1.0 MB	<1	11.2 x 10.4 x 1.9
NORA-B266	nRF54L10	PCB trace	192 kB	1.0 MB	<1	14.3 x 10.4 x 1.9
NORA-B276	nRF54L05	PCB trace	96 kB	0.5 MB	<1	14.3 x 10.4 x 1.9

Table 1: NORA-B2 variants exact characteristics summary

1.5 Radio performance

Table 2 describes the radio characteristics supported by all NORA-B2 module variants.

Item	NORA-B2
Radio	
Supported 2.4 GHz radio modes	Bluetooth LE tested and verified against Bluetooth Core 6.0
Bluetooth LE specification	
Operating channels and frequencies	40 channels, channel numbers 0–39, 2402–2480 MHz
Bluetooth LE data rates	1 Mbps 2 Mbps (LE 2M) 500 kbps (LE Coded, S=2) 125 kbps (LE Coded, S=8)
Typical conducted output power	+7.0 dBm
Radiated output power	+10 dBm including maximum antenna gain (3 dBi)
Conducted RX sensitivity, 1 Mbps	-94 dBm
Conducted RX sensitivity, 2 Mbps	-91 dBm
Conducted RX sensitivity, long range, LE Coded 500 kbps (Coded PHY, S=2)	-97 dBm
Conducted RX sensitivity, long range, LE Coded 125 kbps (Coded PHY, S=8)	-102 dBm

Table 2: NORA-B2 series common characteristics summary

1.6 u-connectXpress software

NORA-B2 series modules come with the pre-flashed u-connectXpress software with integrated Bluetooth protocol stacks. The modules support Bluetooth LE.

For top-grade security, NORA-B2 modules offer secure boot functionality to ensure that the module boots up only with the original u-connectXpress software.

1.6.1 AT command support

NORA-B2 series modules are configured and controlled using high-level AT commands over UART, which eliminates the need for expertise in Bluetooth protocols stacks. For example, users can utilize simple commands to read characteristics from a remote GATT Bluetooth LE service or establish an SPS communication link and perform other functions. See also the u-connectXpress AT commands manual [\[2\]](#).

1.6.2 Software update

NORA-B2 u-connectXpress software incorporates a bootloader that facilitates module flashing over the UART interface. The file download process employs the standard XMODEM protocol.

For information about how to upgrade the software, see also the system integration manual [\[1\]](#).

1.7 Power save modes

NORA-B2 series modules are designed for power efficiency and operate in low-power mode by default. Additional configuration steps are available to further reduce current consumption as needed.

Mode	Description	Remarks
Auto sleep	Module automatically handles power save functions.	All module functions are available.
Auto sleep – with UART RX off	Module automatically handles power save functions. Module receive UART is disabled by the host via AT command.	All module functions are available, but a wake-up signal from the host is required before module can receive AT commands or data via UART.
Deep sleep	Lowest power consumption. Radio is disabled.	The module requires wake up source from host.

Table 3: Power save modes

1.7.1 Wake-up sources

NORA-B2 can wake up from any sleep mode using the peripheral sources shown in [Table 4](#).

Peripheral	Description	Remarks
GPIO_J9	Wake up from “deep sleep” or from “auto sleep – with UART RX off”.	Input signal. Active low.
UART	Wake up from “deep sleep” or from “auto sleep with UART RX off”.	Any activity on UART will wake up the module.

Table 4: Wake-up sources

2 Interfaces

2.1 Power supply

The power for NORA-B2 is supplied through the **VCC** pins with a nominal voltage of 3.3 VDC . This input voltage is also the input/output (I/O) reference for interfacing with external circuitry. The system power supply circuit must be able to support peak power. The current drawn from **VCC** can vary significantly based on Bluetooth LE power consumption profiles. NORA-B2 series modules utilize an integrated voltage regulators to transform and stabilize the supply voltage applied to the **VCC** pins. The voltage converter can operate in “linear low drop-out” mode (LDO) or the default “switching power supply” mode.

2.2 Low frequency clock

NORA-B2 series modules derive their low frequency clock from the internal RC oscillator (LFRC) which is fully embedded in NORA-B2 and does not require external components

 External Crystal oscillator (LFXO) is currently not supported by the u-connectXpress software.

2.3 Module reset

An internal pull-up resistor sets **nRESET** high. To reset (reboot) the module hardware, drive this pin low using an open drain, open collector, or contact switch.

2.4 System control signals

The following input signals are used to control the system:

- **nRESET** is used to reset the system. See also [Module reset](#).
- If both **SWITCH_1** and **SWITCH_2** are driven low during startup, the system enters bootloader mode.
- If both **SWITCH_1** and **SWITCH_2** are driven low during start up and held low for 10 seconds, the system exits bootloader mode and all settings are restored to their factory defaults.

2.5 RF antenna interfaces

NORA-B26 seriesNORA-B2 series (u-connectXpress) modules support either an internal antenna (NORA-B2x6) or external antennas connected through a dedicated antenna pin (NORA-B2x1).

2.5.1 Internal antenna

NORA-B2x6 modules are supplied with internal PCB trace antennas. Tuned for the 2.4 GHz band specifically and designed for optimal performance in the modules.

For more information about antenna-related design, see also the system integration manual [\[1\]](#).

 The **ANT** signal solder pin is not connected on the NORA-B2x6 module.

2.5.2 External RF antenna interface

The NORA-B2x1 module has an antenna signal (**ANT**) pin with a characteristic impedance of 50 Ω for use with an external antenna. The antenna signal supports both Tx and Rx.

For the U.FL reference design and the list of approved antennas, see the) system integration manual [\[1\]](#).

2.6 Data interfaces

2.6.1 UART

The Universal Asynchronous Receiver Transmitter (UART) is an asynchronous serial interface consisting of up to four signals: transmit data (**UART_TXD**), receive data (**UART_RXD**), request-to-send (**UART_RTS**) handshake, and clear-to-send (**UART_CTS**) handshake. The handshake signals are optional but are recommended at higher speeds. Default port settings are 115200 bps, 8 data bits, no parity, 1 stop bit. Maximum baud rate is 1 Mbps.

3 Pin definition

The following chapters describe the module pin layout and functions.

3.1 Pin assignment

Figure 2 describes the pin layout and pin number assignments.

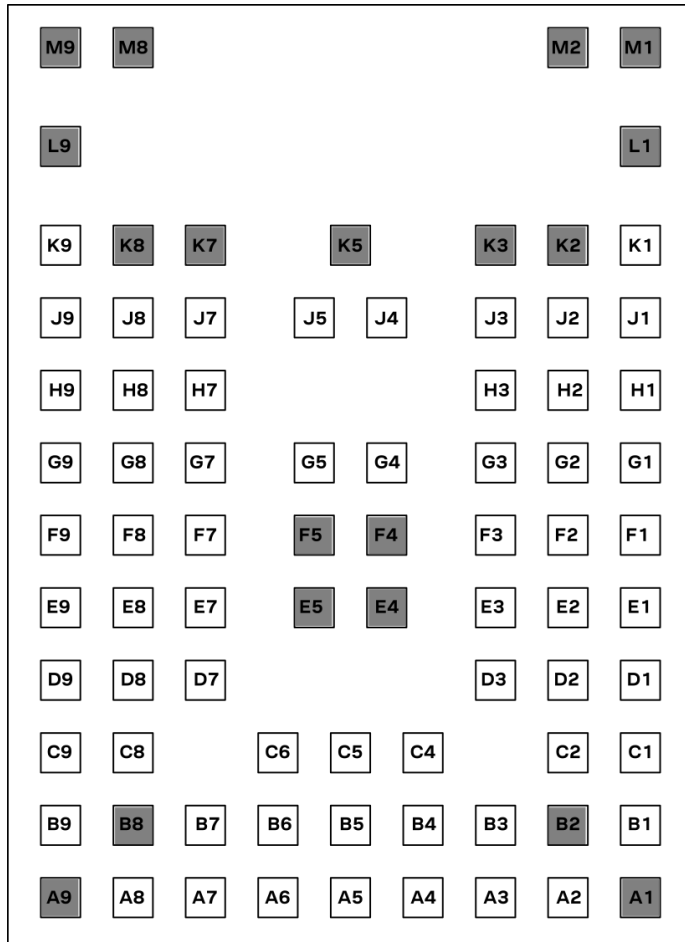

Figure 2: Pin assignment (top view)



GND pins are shown in gray in Figure 2.



Pads L1, L9, M1, M2, M8 and, M9 are only available on NORA-B2x6 variants

3.2 Pinout

Table 5 shows the default module pin-out assignments of the NORA-B2 module.

No.	Name	Function	Description	Remarks
A1	GND	Ground	Ground pad	
A2	n/c	-	No connection	
A3	RSVD_A3	I/O	Reserved – do not connect	
A4	n/c	-	No connection	
A5	DBG_TX	Output	Debug UART TX data	
A6	RSVD_A6	Input	Reserved – do not connect	
A7	VCC	Power	Power supply input and I/O reference voltage	

No.	Name	Function	Description	Remarks
A8	VCC	Power	Power supply input and I/O reference voltage	
A9	GND	Ground	Ground pad	
B1	RSVD_B1	Input	Reserved – do not connect	
B2	GND	Ground	Ground pad	
B3	RSVD_B3	Output	Reserved – do not connect	
B4	RSVD_B4	I/O	Reserved – do not connect	
B5	NFC2	I	NFC antenna connection (not yet supported)	
B6	RSVD_B6	I/O	Reserved – do not connect	
B7	VCC	Power	Power supply input and I/O reference voltage	
B8	GND	Ground	Ground pad	
B9	n/c	-	No connection	
C1	RSVD_C1	Output	Reserved – do not connect	
C2	RSVD_C2	Input	Reserved – do not connect	
C4	RSVD_C4	I/O	Reserved – do not connect	
C5	NFC1	I	NFC antenna connection (not yet supported)	
C6	RSVD_C6	I/O	Reserved – do not connect	
C8	SWITCH_2	Input	Switch 2	Internally pulled high, 14 kΩ
C9	n/c	-	No connection	
D1	RSVD_D1	I/O	Reserved – do not connect	
D2	RSVD_D2	I/O	Reserved – do not connect	
D3	n/c	-	No connection	
D7	n/c	-	No connection	
D8	SWITCH_1	Input	Switch 1	Internally pulled high, 14 kΩ
D9	n/c	-	No connection	
E1	RSVD_E1	I/O	Reserved – do not connect	
E2	RSVD_E2	I/O	Reserved – do not connect	
E3	n/c	-	No connection	
E4	GND	Ground	Ground pad	
E5	GND	Ground	Ground pad	
E7	n/c	-	No connection	
E8	GPIO_E8	I/O	GPIO ¹	Output only when configured for WAKE_HOST function
E9	GPIO_E9	I/O	GPIO ¹	
F1	RSVD_F1	I/O	Reserved – do not connect	
F2	RSVD_F2	I/O	Reserved – do not connect	
F3	n/c	-	No connection	
F4	GND	Ground	Ground pad	
F5	GND	Ground	Ground pad	
F7	n/c	-	No connection	
F8	UART_RTS	Output	UART_RTS	
F9	UART_CTS	Input	UART_CTS	
G1	n/c	-	No connection	
G2	n/c	-	No connection	
G3	n/c	-	No connection	

¹ GPIO and WAKE_HOST not yet supported

No.	Name	Function	Description	Remarks
G4	n/c	-	No connection	
G5	RSVD_G5	I/O	Reserved – do not connect	
G7	RSVD_G7	I/O	Reserved – do not connect	
G8	UART_TXD	Output	UART_TXD	
G9	UART_RXD	Input	UART_RXD	
H1	n/c	-	No connection	
H2	RSVD_H2	I/O	Reserved – do not connect	
H3	n/c	-	No connection	
H7	n/c	-	No connection	
H8	GREEN	Output	Green LED	Active low
H9	BLUE	Output	Blue LED	Active low
J1	n/c	-	No connection	
J2	RSVD_J2	Output	Reserved – do not connect	
J3	nRESET	Input	External system reset input	Internally pulled high, 14 kΩ
J4	n/c	-	No connection	
J5	n/c	-	No connection	
J7	n/c	-	No connection	
J8	RED	Output	Red LED	Active low
J9	GPIO_J9	I/O	WAKE_UP from sleep	Input only when configured as WAKE_UP (see Table 4)
K1	n/c	-	No connection	
K2, K3, K5, K7, K8	GND	Ground	Ground pad	
K9	ANT	Antenna	NORA-B2x1: Antenna interface NORA-B2x6: No connection	50 Ω nominal characteristic impedance
L1, L9, M1, M2, M8, M9	GND	Ground	Ground pad	Only available on NORA-B2x6

Table 5: NORA-B2 pinout

4 Electrical specifications

Stressing the device above one or more of the [absolute maximum ratings](#) can cause permanent damage. These are stress ratings only. Operating the module at these or at any conditions other than those specified in the [recommended operating conditions](#) should be avoided. Exposure to absolute maximum rating conditions for extended periods may affect device reliability.

All given application information is only advisory and does not form part of the specification.

4.1 Absolute maximum ratings

Signal	Description	Condition	Min	Max	Unit
VCC	Module supply high voltage	Input DC voltage at VCC pin	-0.3	3.8	V
V _{I/O}	Input DC voltage at any digital I/O pin	VCC ≤ 3.5 V	-0.3	VCC + 0.3	V
		VCC > 3.5 V	-0.3	3.8	V
P_ANT	Maximum power at the receiver	Input RF power at the antenna pin		0	dBm
I _{NFC1/2}	NFC Antenna pin current	Input current at NFC pin		130	mA

Table 6: Absolute maximum ratings

The product is not protected against overvoltage or reversed voltages. Use appropriate protection devices to ensure that voltage spikes exceeding the power supply voltage specifications in [Table 6](#) are kept within the specified limits.

4.1.1 Maximum ESD ratings

Parameter	Min	Typical	Max	Unit	Remarks
ESD sensitivity for all pins except ANT pin			1	kV	Determined according to JEDEC Standard JESD22-A114, Electrostatic Discharge (ESD) Sensitivity Testing Human Body Model (HBM).
ESD sensitivity for all pins except ANT pin			500	V	Charged device model according to JESD22-C101
ESD indirect contact discharge			±8*	kV	According to EN 301 489-1

*Tested on EVK-NORA-B20 evaluation board

Table 7: Maximum ESD ratings

NORA-B26 series NORA-B2 series (u-connectXpress) modules are Electrostatic Sensitive Devices and require special precautions while handling. For ESD handling instructions, refer to also [ESD precautions](#).

4.1.2 Non-volatile memory endurance

Parameter	Value	Unit
Endurance	10,000	Write/rewrite cycles
Retention	10	Years at 85 °C

Table 8: NVM endurance

4.2 Recommended operating conditions

Unless otherwise specified, all given specifications have been measured at an ambient temperature of 25 °C with a supply voltage of 3.3 V.

Operation beyond the specified operating conditions is not recommended and extended exposure beyond them may affect device reliability.

4.2.1 Operating and storage temperature range

Parameter	Min	Typ	Max	Unit
Storage temperature	-40		+105	°C
Operating temperature	-40	+25	+85	°C

Table 9: Temperature range

4.2.2 Supply/power pin

Symbol	Parameter	Min	Typ	Max	Unit
VCC	NORA-B2 module supply voltage	1.7	-	3.5	V
VCC _{POR}	VCC supply voltage during power-on reset	1.75	-	-	V

Table 10: Input characteristics of voltage supply pins

4.2.3 RESET_N pin

See Table 10 for the requirement for VCC supply voltage during power-on reset (VCC_{POR}).

Pin name	Parameter	Min	Typ	Max	Unit
RESET_N	Time measured as time in power-on reset after supply reaches minimum operating voltage, with VCC rise time from 1 μs to 100 ms		0.2	2	ms

Table 11: RESET_N pin characteristics

4.2.4 Digital pins

Condition	Min	Typ	Max	Unit
Input high voltage	0.7 x VCC		VCC	V
Input low voltage	GND		0.3 x VCC	V
Output high voltage, standard drive, 0.5 mA, VCC ≥ 1.7	VCC-0.4		VCC	V
Output high voltage, high drive, 5 mA, VCC ≥ 2.7 V	VCC-0.4		VCC	V
Output high voltage, high drive, 3 mA, VCC ≥ 1.7 V	VCC-0.4		VCC	V
Output low voltage, standard drive, 0.5 mA, VCC ≥ 1.7	GND		GND+0.4	V
Current at GND+0.4 V, output set low, standard drive, VCC ≥ 1.7	1	3	4	mA
Current at GND+0.4 V, output set low, high drive, VCC ≥ 1.7 V	3			mA
Current at GND+0.4 V, output set low, extra drive, VCC ≥ 1.7 V	16			mA
Current at VCC-0.4 V, output set high, standard drive, VCC ≥ 1.7	1	3	4	mA
Current at VCC-0.4 V, output set high, high drive, VCC ≥ 1.7 V	4			mA
Current at VCC-0.4 V, output set high, extra drive, VCC ≥ 1.7 V	14			mA
Recommended maximum sustained current drawn by all GPIOs			15	mA
Rise/Fall time, high drive mode, 20-80%, 12 pF load		4		ns
Rise/Fall time, extra drive mode, 20-80%, 12 pF load		0.9		ns
Pull-up resistance	12	14	16	kΩ
Pull-down resistance	12	14	18	kΩ

Table 12: Digital pin characteristics

4.2.5 Current consumption

The typical current consumption of a NORA-W26 module is shown in [Table 13](#). The current consumption is highly dependent on the application implementation. Measurements are taken at 115200 baud rate, 40 ms connection interval, UART RX On, 25 °C with a 3.3 V supply, using u-connectXpress v3.0.0.

Radio mode	Role	Activity		Consumption	Unit
Off		System Idle	Avg. current	141	µA
Off		UART RX Off	Avg. current	7	µA
Off		CPU in deep sleep	Avg. current	1	µA
Bluetooth LE	Central	Bluetooth idle	Avg. current	141	µA
		Bluetooth scan	Avg. current	2.53	mA
		Bluetooth connected (idle)	Avg. current	191	µA
	Peripheral	Bluetooth idle	Avg. current	141	µA
		Bluetooth advertising	Avg. current	147	µA
		Bluetooth connected (idle)	Avg. current	208	µA

Table 13: Typical current consumption

4.2.6 Throughput performance

The throughput shown in [Table 14](#) was measured in a conducted setup using u-connectXpress version 3.0.0. For descriptions of the different transfer modes, see the system integration manual [\[1\]](#).

Radio mode	Transfer mode	Direction	Baud rate	Connection Interval	Throughput	Protocol	Remarks
Bluetooth Coded PHY	Transparent	UL	1 Mbps	-	- kbps	SPS	Central or peripheral
	Transparent	DL	1 Mbps	-	- kbps	SPS	Central or peripheral
	AT	UL	1 Mbps	-	- kbps	SPS	Central or peripheral
	AT (direct)	DL	1 Mbps	-	- kbps	SPS	Central or peripheral
	AT (buffered)	DL	1 Mbps	-	- kbps	SPS	Central or peripheral
Bluetooth LE1M PHY	Transparent	UL	1 Mbps	12.5 ms	410 kbps	SPS	Central or peripheral
	Transparent	DL	1 Mbps	12.5 ms	410 kbps	SPS	Central or peripheral
	AT	UL	1 Mbps	-	- kbps	SPS	Central or peripheral
	AT (direct)	DL	1 Mbps	20 ms	419 kbps	SPS	Central or peripheral
	AT (buffered)	DL	1 Mbps	12.5 ms	482 kbps	SPS	Central or peripheral
Bluetooth LE2M PHY	Transparent	UL	1 Mbps	20 ms	608 kbps	SPS	Central or peripheral
	Transparent	DL	1 Mbps	20 ms	608 kbps	SPS	Central or peripheral
	AT	UL	1 Mbps	-	- kbps	SPS	Central or peripheral
	AT (direct)	DL	1 Mbps	-	- kbps	SPS	Central or peripheral
	AT (buffered)	DL	1 Mbps	-	- kbps	SPS	Central or peripheral

Table 14: Throughput performance

4.2.7 RF performance

Parameter	Test condition	Min	Typ	Max	Unit
Bluetooth LE mode					
Receiver input sensitivity*	Conducted at 25 °C, 1 Mbit/s Bluetooth LE mode		-94		dBm
	Conducted at 25 °C, 2 Mbit/s Bluetooth LE mode		-91		dBm
	Conducted at 25 °C, 500 kbit/s Bluetooth LE mode		-97		dBm
	Conducted at 25 °C, 125 kbit/s Bluetooth LE mode		-102		dBm
Maximum output power	Conducted at 25 °C		+7		dBm
Antenna					
NORA-B2x6 antenna gain	Internal to EVK-NORA-B2x6		+3		dBi

*Conducted test on EVK-NORA-B201 evaluation board.

Table 15: NORA-B2 RF performance

4.2.8 Antenna radiation patterns

Figure 3 provides an overview of the measurement procedure and describes how the NORA-B2x6 module is aligned to the XYZ-coordinate system. A measurement is taken at every dotted position above the module image (shown left). Each measurement is represented as a grid point in the radiation pattern (shown right).

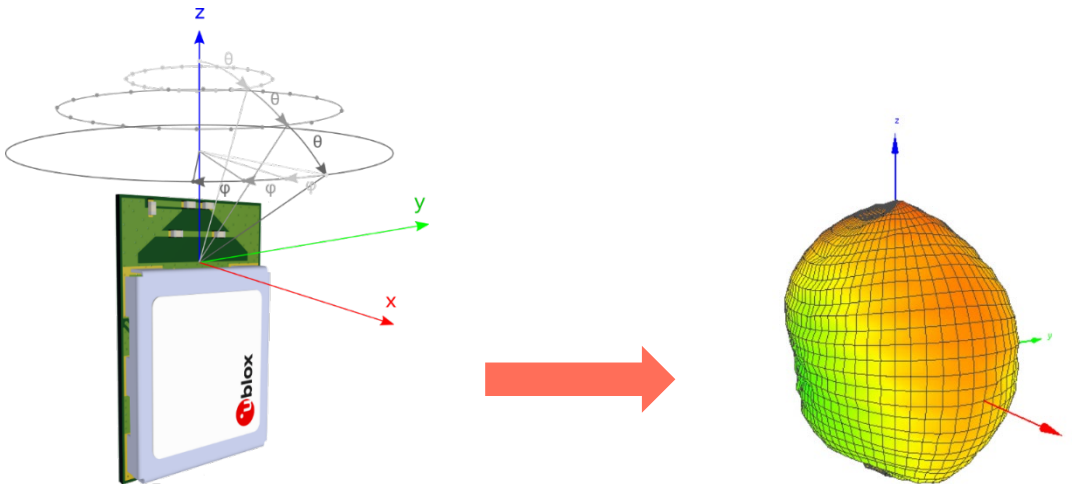
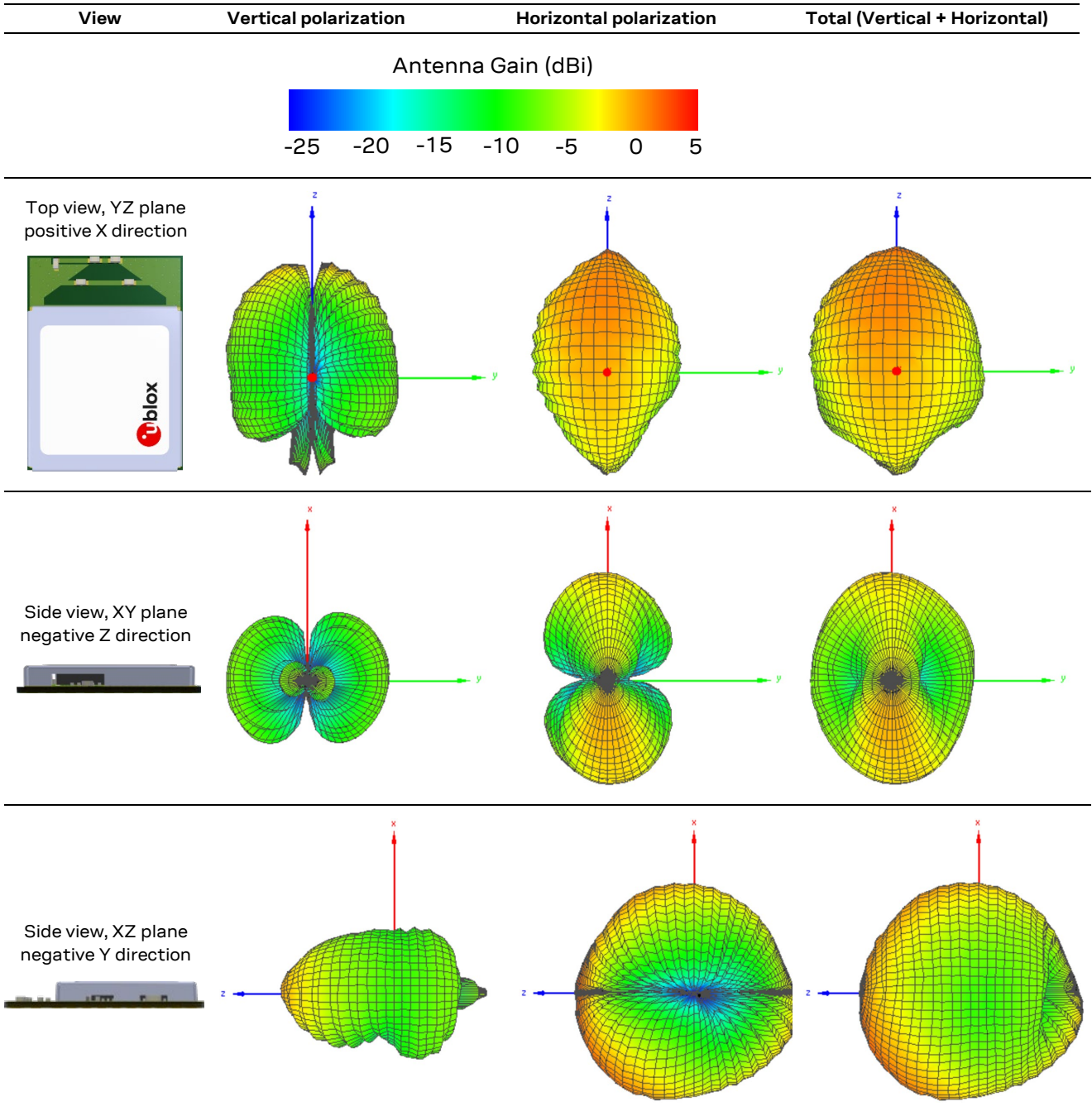

Figure 3: Spherical test points

Table 16 shows the displayed radiation patterns of the internal PCB trace antenna on NORA-B2x6.



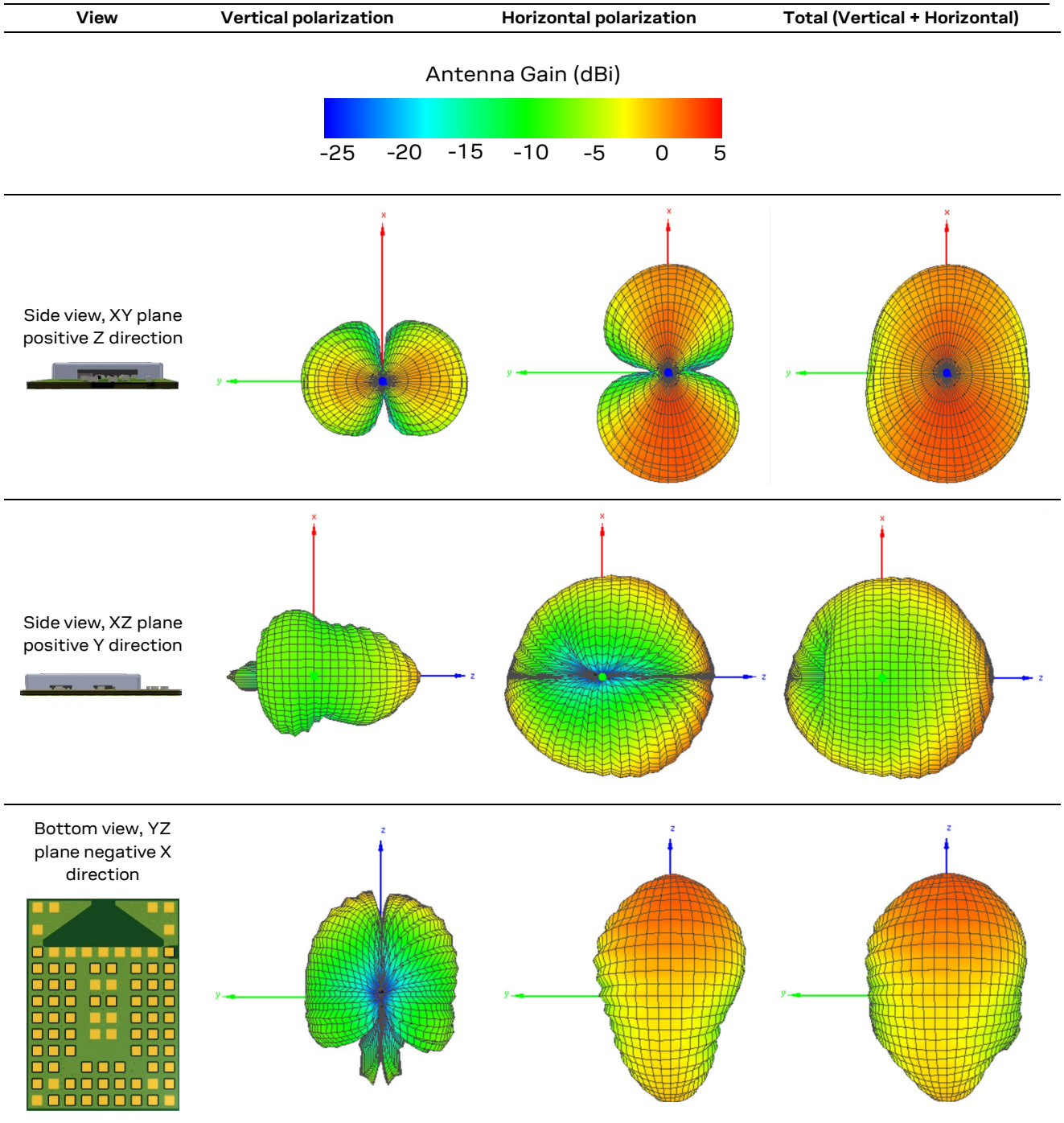
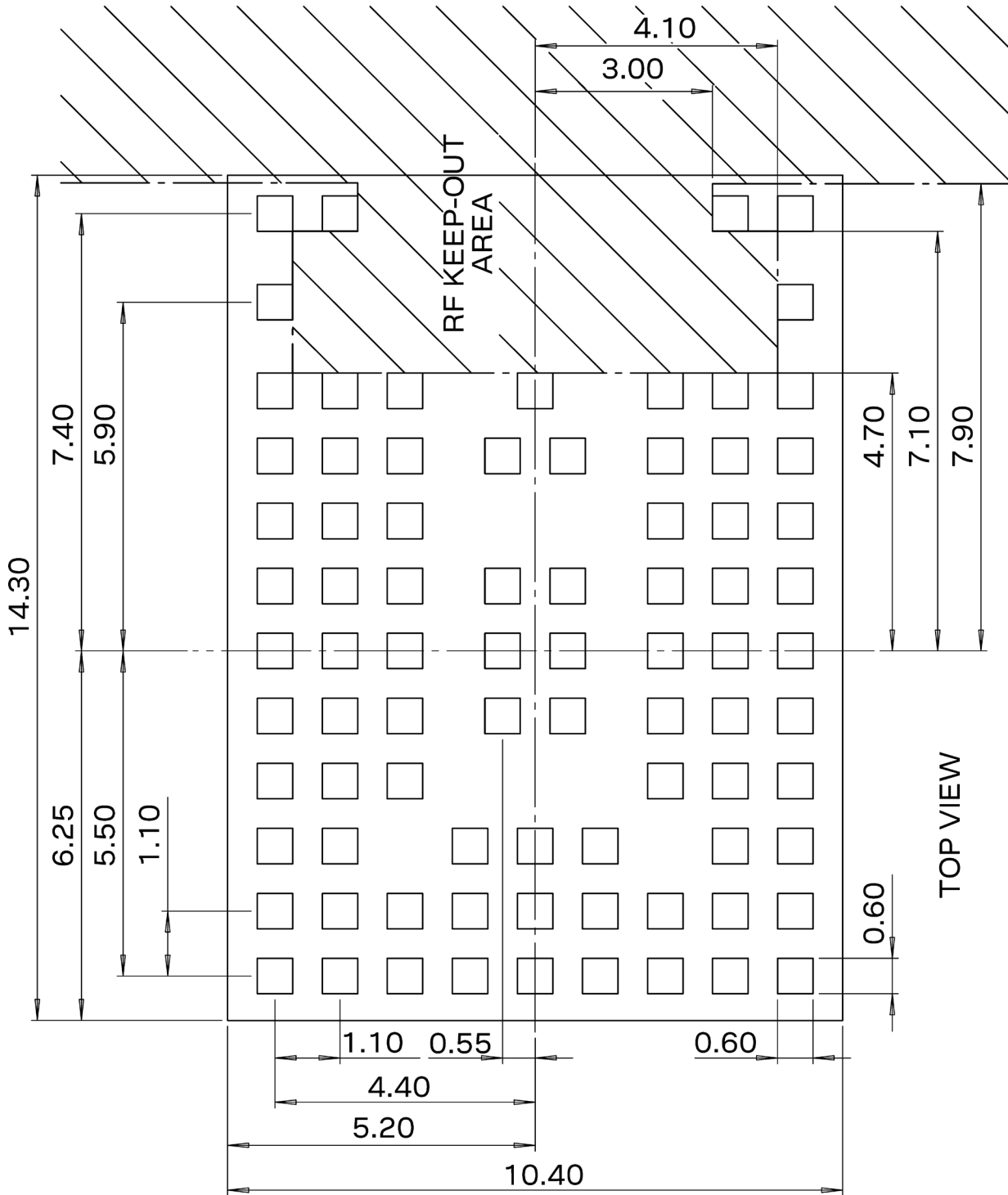

Table 16: NORA-B2x6 antenna radiation patterns

5 Mechanical specifications

5.1 NORA-B2 footprint dimensions

Figure 4 shows the common footprint and dimensions of NORA-B2x6 modules, while Figure 5 shows the common footprint and dimensions of NORA-B2x1 modules. Nominal values are used.



All dimensions in mm.

Figure 4: NORA-B2x6 footprint dimensions

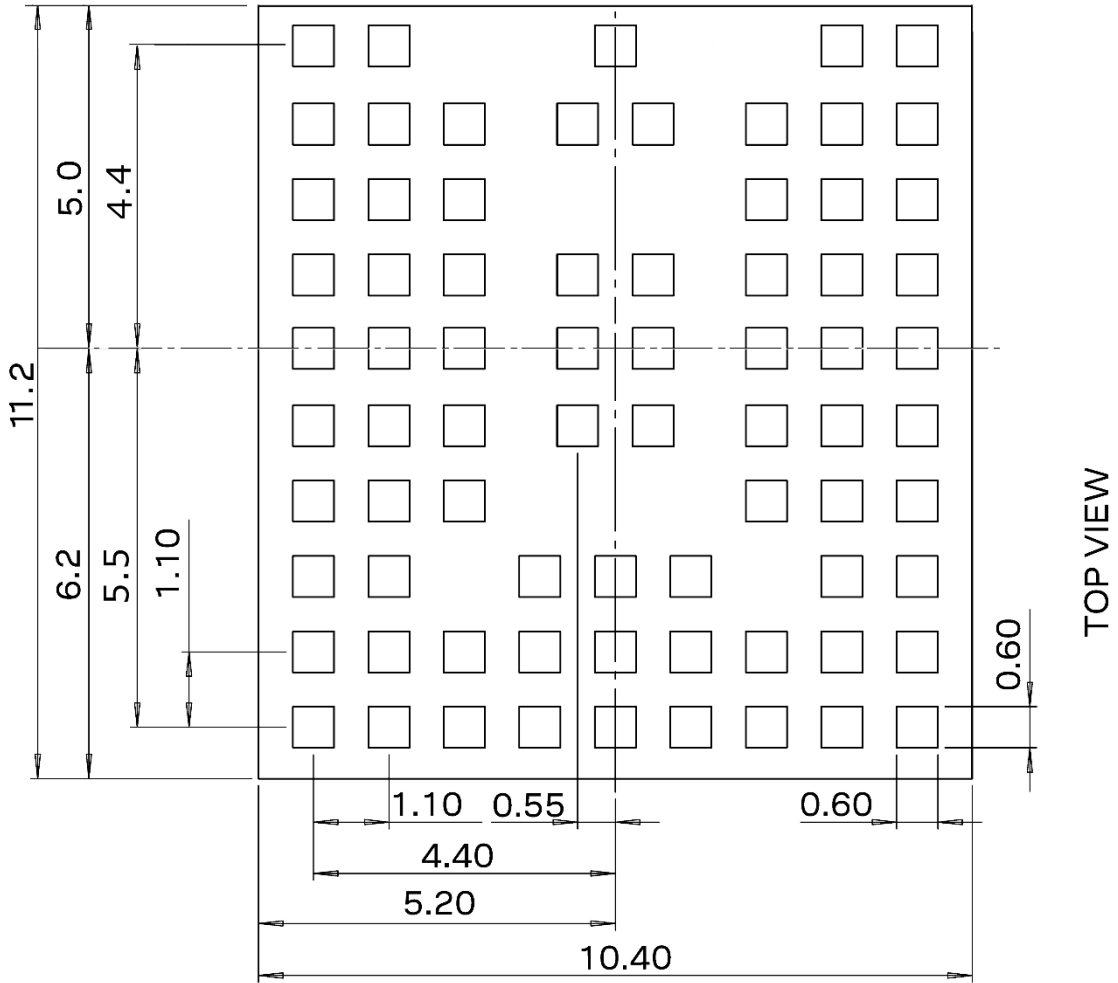

All dimensions in mm.

Figure 5: NORA-B2x1 footprint dimensions

5.2 NORA-B2 mechanical specification

5.2.1 NORA-B2x6 mechanical specifications

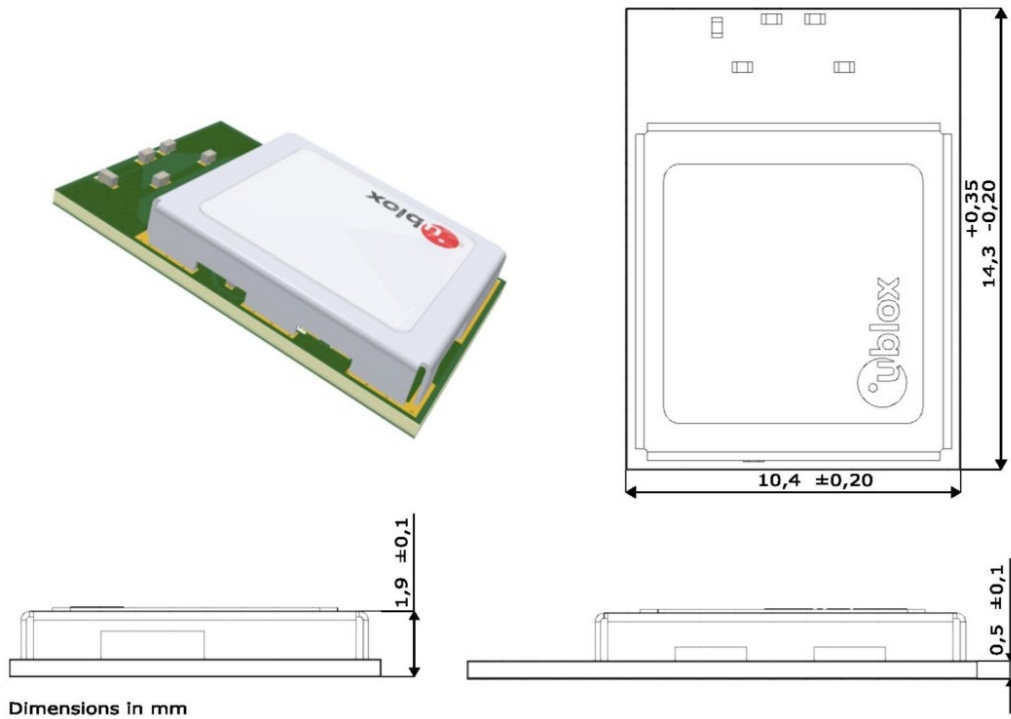

Figure 6: NORA-B2x6 mechanical specification

5.2.2 NORA-B2x1 mechanical specification

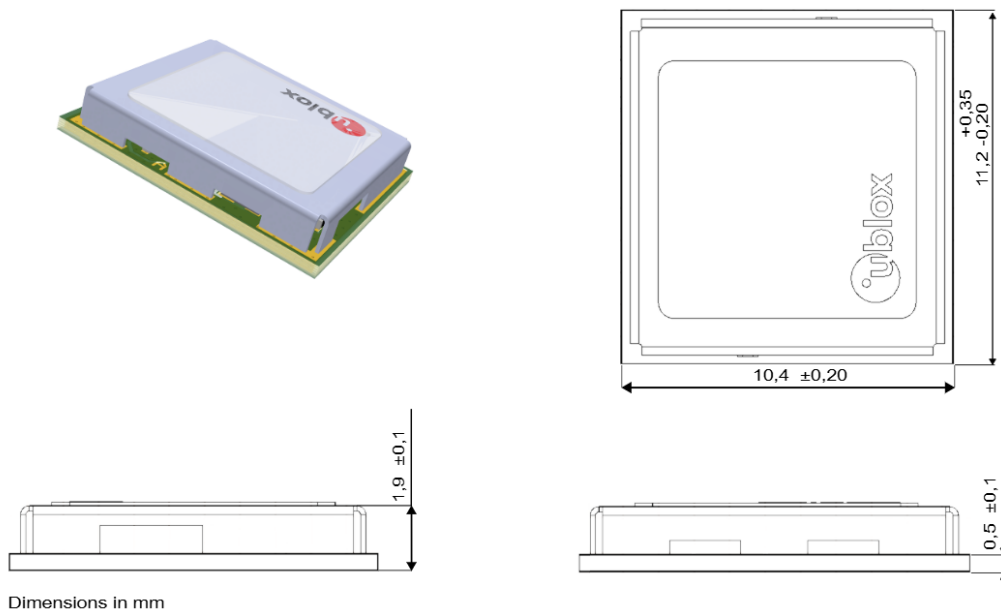

Figure 7: NORA-B2x1 mechanical specification

6 Qualifications and approvals

6.1 Country approvals

NORA-B2 modules are certified for use in the following countries/regions:

Country/region	NORA-B2x1	NORA-B2x6
Europe	Approved	Approved
Great Britain (UKCA)	Approved	Approved
USA	Approved	Approved
Canada	Approved	Approved
Japan	Approved	Approved
South Korea	Approved	Approved
Australia	Approved	Approved
New Zealand	Approved	Approved
Taiwan	Approved	Approved

Table 17: Country approvals

 For detailed information about the regulatory requirements that must be met for all end-product applications based on NORA-B2 modules, refer to the system integration manual [1].

6.2 Bluetooth qualification



All products that use Bluetooth technology must be qualified with the Bluetooth Special Interest Group (SIG). This is also applicable for products that are using an already Bluetooth-qualified module.

Product declarations are submitted through the SIG [Bluetooth SIG Qualification Workspace](#).

The NORA-B2 series modules are qualified as a Core-Controller Configuration against Bluetooth core 6.0.

To list your product that integrates NORA-B2 with no additional testing required, combine the DN (Device Number) for the Bluetooth stack implemented in the Core-Host Configuration with the DN of the Core-Controller Configuration shown in [Table 18](#).

Product name	Product type	DN	Product qualification date
NORA-B261, NORA-B266, NORA-B276	Core-Controller Configuration	Q364310	2025-08-05

Table 18: NORA-B2 series Bluetooth Design Number

7 Product handling

7.1 Packaging

NORA-B26 seriesNORA-B2 series (u-connectXpress) modules are delivered as hermetically sealed, reeled tapes to enable efficient production, production lot set-up and tear-down. For more information about packaging, refer to also the Packaging information reference guide [3].

7.1.1 Reels

NORA-B26 seriesNORA-B2 series (u-connectXpress) modules are deliverable in quantities of 500 pieces on a reel. The reel types for the modules are shown in Table 19.

For more detailed information, see also the Packaging information reference guide [3].

Model	Reel type
NORA-B261	A3
NORA-B266	A3
NORA-B276	A3

Table 19: Reel types for different models of the NORA-B26 seriesNORA-B2 series (u-connectXpress)

7.1.2 Tapes

Figure 8 and Figure 9 shows the position and orientation of the NORA-B26 seriesNORA-B2 series (u-connectXpress) modules as they are delivered on tape. The dimensions of the tapes are specified in Figure 10 and Figure 11.

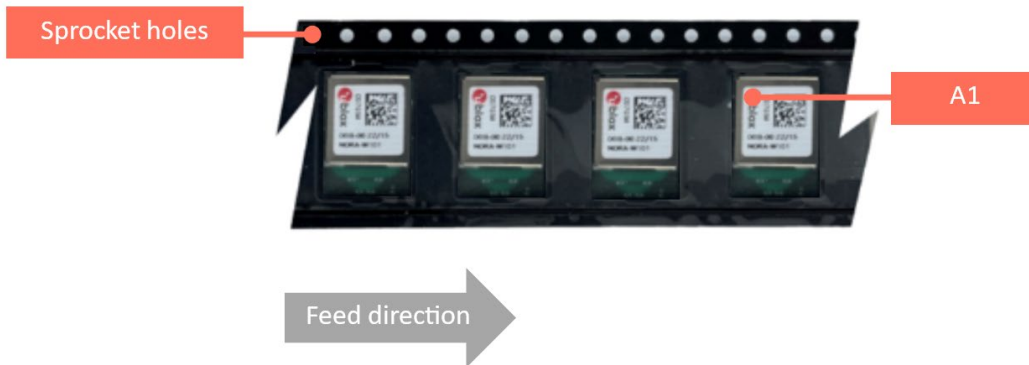

Figure 8: Orientation of NORA-B2x6 module on tape

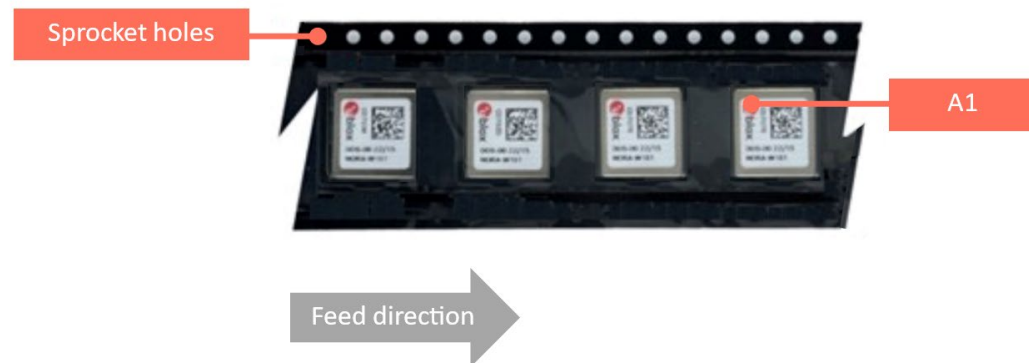

Figure 9: Orientation of NORA-B2x1 module on tape

Figure 10 shows the tape and pocket dimensions for NORA-B2x6.

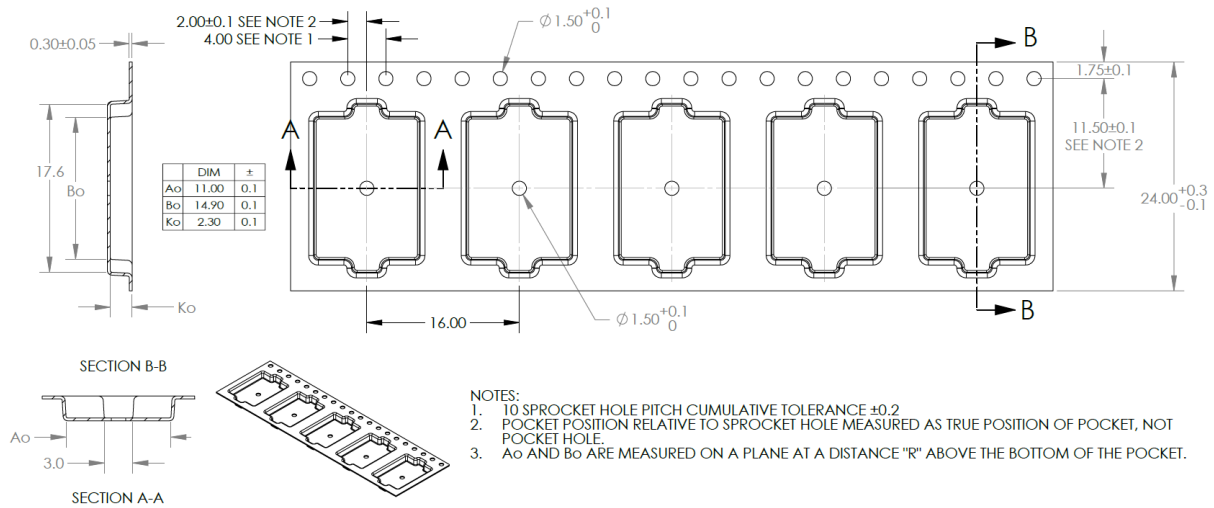

Figure 10: Tape and pocket dimensions for NORA-B2x6

Figure 11 shows the tape and pocket dimensions for NORA-B2x1

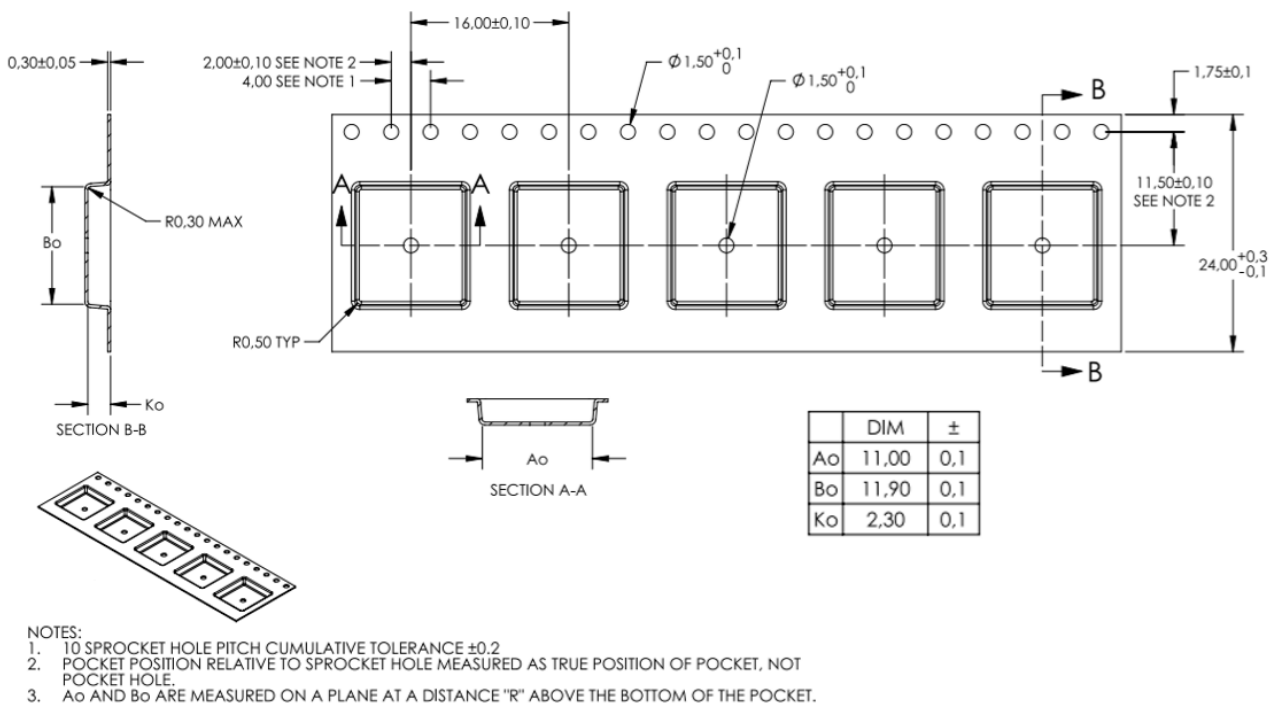



Figure 11: Tape and pocket dimensions for NORA-B2x1

7.2 Moisture sensitivity levels

NORA-B26 seriesNORA-B2 series (u-connectXpress) modules are classified as Moisture Sensitive Devices (MSD) in accordance with the IPC/JEDEC specification.

The Moisture Sensitivity Level (MSL) relates to the required packaging and handling precautions.

-  NORA-B2 series modules are rated at **MSL level 4** in accordance with the IPC/JEDEC J-STD-020 standard. For detailed information, see the moisture sensitive warning label on the MBB (Moisture Barrier Bag).

After opening the dry pack, the modules must be mounted within 72 hours in factory conditions of maximum 30 °C/60%RH or must be stored at less than 10% RH. The modules require baking if the humidity indicator card shows more than 10% when read at 23±5 °C or if the conditions mentioned above are not met. For information about the bake procedure, see also the J-STD-033B standard.

For more information regarding moisture sensitivity levels, labeling and storage, see the Packaging information reference guide [\[3\]](#).

-  For MSL standards, see also IPC/JEDEC J-STD-020 and IPC/JEDEC J-STD-033B. The standards can be downloaded from the JEDEC website [\[5\]](#).

7.3 Reflow soldering

Reflow profiles are selected according to u-blox recommendations. See the system integration manual [\[1\]](#) for more information.

-  Failure to follow these recommendations can result in severe damage to the device.

7.4 ESD precautions

-  NORA-B26 seriesNORA-B2 series (u-connectXpress) modules contain highly sensitive electronic circuitry and are Electrostatic Sensitive Devices (ESD). Handling the NORA-B26 seriesNORA-B2 series (u-connectXpress) modules without proper ESD protection may destroy or damage them permanently.

NORA-B26 seriesNORA-B2 series (u-connectXpress) modules are electrostatic sensitive devices (ESD) and require special ESD precautions typically applied to the ESD sensitive components. See also [Maximum ESD ratings](#).



Proper ESD handling and packaging procedures must be applied throughout the processing, handling, and operation of any application that incorporates the NORA-B26 seriesNORA-B2 series (u-connectXpress) module. Failure to observe these recommendations can result in severe damage to the device.

8 Labeling and ordering information

The labels on NORA-B2 series modules include important product information.

8.1 Module marking

Figure 12 shows the label applied to NORA-B2 series modules. Each of the label references given is described in Table 20.

All units in mm unless specified otherwise.

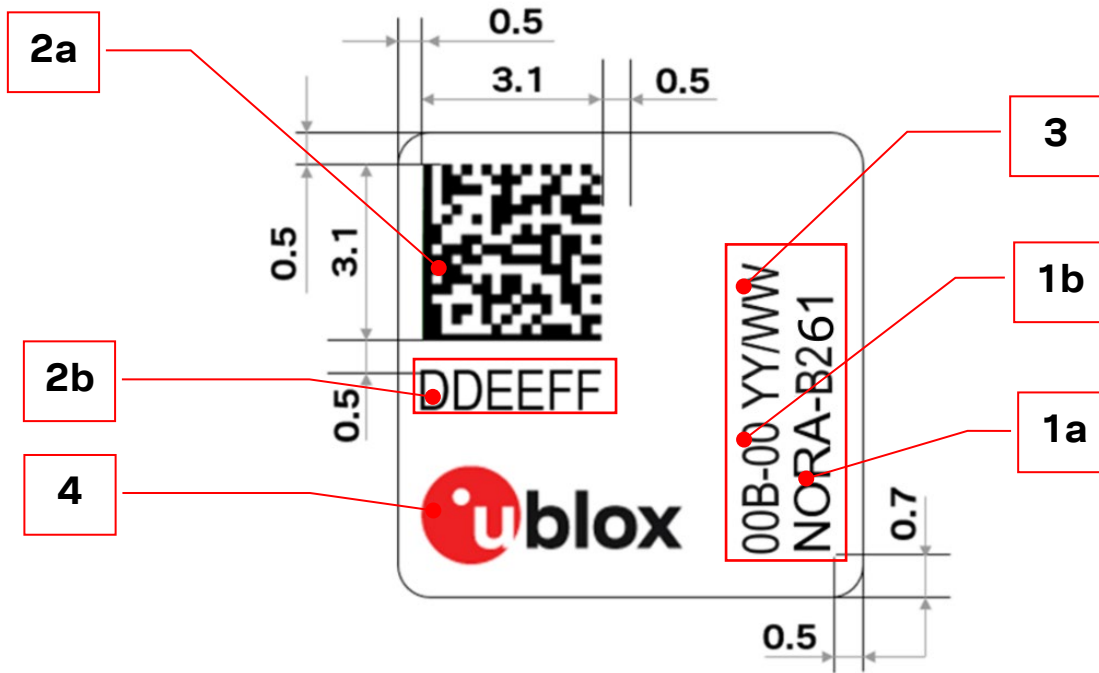

Figure 12: NORA-B26 series NORA-B2 series (u-connectXpress) module marking

Reference	Description
1a	Text box containing Product Name and approval ID:s (Applicable model names: NORA-B2xx).
1b	Product type number.
2a	Data Matrix with unique serial number comprising 19 alphanumeric digits: (product identifier, serial number, datacode) <ul style="list-style-type: none"> Product identifier: 3 digits, used for production tracking and are an abbreviated representation of the Type number that is unique to each module variant Serial number: 12 digits, Unique MAC address assigned during module production. Datacode: 4 digits, Represent the hardware and firmware version encoded.
2b	The six last hex symbols of the MAC address (AABBCCDDEEFF).
3	Date of production encoded YY/WW (year/week).
4	u-blox logo. The red dot also indicates pin 1.

Table 20: NORA-B26 series NORA-B2 series (u-connectXpress) module marking

8.2 Product identifiers

Table 21 describes the three product identifiers, namely the Type number, Model name and Ordering code.

Format	Description	Nomenclature
Model name	Describes the form factor, platform technology and platform variant. Used mostly in product documentation like this data sheet, the model name represents the most common identity for all u-blox products.	PPPP-TGVV
Ordering code	Comprises the model name – with additional identifiers to describe the major product version and quality grade.	PPPP-TGVV-TTQ
Type number	Comprises the model name and ordering code – with additional identifiers to describe minor product versions.	PPPP -TGVV-TTQ-XX

Table 21: Product code formats

8.3 Identification codes

Table 22 explains the parts of the product code.

Code	Meaning	Example
PPPP	Form factor	NORA
TG	Platform (Technology and Generation) T – Dominant technology, for example, W: Wi-Fi, B: Bluetooth G - Generation	B2: Bluetooth Generation 2 of NORA form factor
VV	Variant based on the same platform; range [00...99]	01: default configuration, with antenna pin
TT	Major product version	00: first revision
Q	Quality grade A: Automotive B: Professional C: Standard	B: professional grade
XX	Minor product version (not relevant for certification)	Default value is 00

Table 22: Part identification code

8.4 Ordering information

Ordering Code	Product
NORA-B261-00B	NORA-B2 module with antenna pin, based on nRF54L10, u-connectXpress v3.0.1
NORA-B266-00B	NORA-B2 module with internal PCB antenna, based on nRF54L10, u-connectXpress v3.0.1
NORA-B276-00B	NORA-B2 module with internal PCB antenna, based on nRF54L05, u-connectXpress v3.2.0

Table 23: Product ordering codes

Appendix

A Glossary

Abbreviation	Definition
ADC	Analog to Digital Converter
AoA	Angle of Arrival
AoD	Angle of Departure
BPF	Band Pass Filter
CBC-MAC	Cipher block chaining - message authentication code
CCM	Counter with cipher block chaining - message authentication code
CMAC	Cipher-based Message Authentication Code
CPU	Central Processing Unit
CTI	Cross Trigger Interface
CTR	AES CCM combines counter
CTS	Clear To Send
DC	Direct Current
DMA	Direct Memory Access
DPPI	Distributed Programmable Peripheral Interconnect
DWT	Data Watchpoint and Trace
ECB	Electronic CodeBook
EDM	Extended Data Mode
ESD	ElectroStatic Discharge
ETM	Embedded Trace Macrocell
FCC	Federal Communications Commission (United States)
FEM	Front End Module
FLPR	Fast Lightweight Peripheral Processor
FPU	Floating Point Unit
GATT	Generic ATtribue profile
GCM	Galois/Counter Mode
GPIO	General Purpose Input/Output
I2C	Inter-Integrated Circuit
ISED	Innovation, Science and Economic Development (Canada)
IEEE	Institute of Electrical and Electronics Engineers
IPC	Inter-Processor Communication
ITM	Instrumentation Trace Macrocell
LE	Low Energy
LNA	Low Noise Amplifier
MUTEX	Mutually Exclusive
NFC	Near Field Communication
OEM	Original Equipment Manufacturer
OTP	One-Time Programmable
OUI	Organizationally Unique Identifier
PA	Power Amplifier
PDM	Pulse Density Modulation
PWM	Pulse Width Modulation

Abbreviation	Definition
QDEC	Quadrature DECoder
QSPI	Quad Serial Peripheral Interface
RAM	Random Access Memory
RNG	Random Number Generator
GRTC	Global Real-Time Counter
RTLS	Real-Time Location Service
RTS	Request To Send
SDK	Software Development Kit
SPI	Serial Peripheral Interface
SWD	Serial Wire Debug
TWI	Two-Wire Interface (See I2C)
UART	Universal Asynchronous Receiver/Transmitter
UICR	User Information Control Registers
WDT	WatchDog Timer
XIP	eXecute In Place

Table 24: Explanation of the abbreviations and terms used

Related documents

- [1] NORA-B2 (u-connectXpress) system integration manual, [UBXDOC-465451970-2534](#)
- [2] NORA-B26 AT Command Manual, <https://www.u-blox.com/en/sho-online-documentation/nora-b26/at-manual>,
NORA-B27 AT Command Manual, <https://www.u-blox.com/en/sho-online-documentation/nora-b27/at-manual>,
- [3] Packaging information reference guide, [UBX-14001652](#)
- [4] Nordic Semiconductor [nRF54L15_nRF54L10_nRF54L05 Datasheet](#)
- [5] JEDEC [website](#)

 For product change notifications and regular updates of u-blox documentation, register on our website, www.u-blox.com.

Revision history

Revision	Date	Name	Comments
R01	19-Aug-2025	habd	Initial release
R02	01-Okt-2025	habd, fkru	Updates according to the Nordic datasheet v.10: Absolute maximum ratings VCC (Max), Added VCC supply voltage needed during power-on reset in Table 10 . Updates to Country approvals . Minor updates and documentation improvements throughout the document.
R03	8-Dec-2025	whsu	Added variant NORA-B27. Minor documentation improvements throughout the document.

Contact

u-blox AG

Address: Zürcherstrasse 68
8800 Thalwil
Switzerland

For further support and contact information, visit us at www.u-blox.com/support.