

## Application Note

# SMD Digital Pyroelectric Infrared Sensor

**IRS-D200ST00R1**

Version 3 2024.04

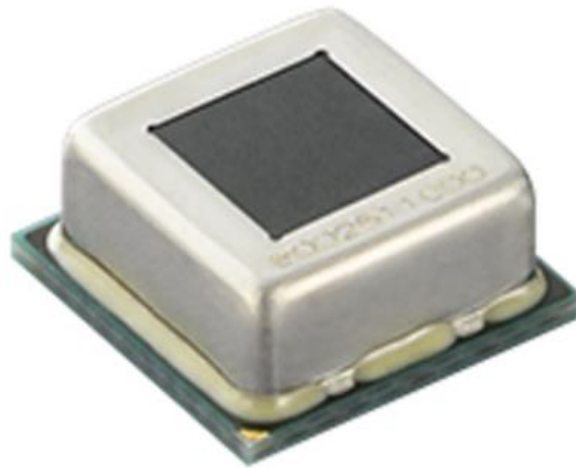

### Features and Benefits

- ✓ Small size / Low profile
- ✓ SMD (Reflow soldering applicable)
- ✓ Low supply current
- ✓ Digital output (I<sup>2</sup>C)
- ✓ High – resolution output
- ✓ MCU Wake-up by Interrupt signal
- ✓ Setting adjustable interrupt conditions to avoid false detection
- ✓ Variable filter characteristic
- ✓ High RF noise immunity
- ✓ Internal circuit (Including Pre-AMP)

### Applications

- ✓ IP Camera
- ✓ Doorbell
- ✓ Thermostat
- ✓ IoT Devices
  - Wireless devices
  - Battery devices
  - Low power motion detection devices
- ✓ Lighting control
- ✓ Home appliances

# CONTENTS

## 1. General Information

- 1.1 Introduction
- 1.2 Image of how to use
- 1.3 Product figures / dimensions / spec.
- 1.4 Pin Configurations and Land pattern
- 1.5 Circuit example
- 1.6 Reflow profile

## 2. Data Communication

- 2.1 I<sup>2</sup>C interface
- 2.2 I<sup>2</sup>C I/F functions
- 2.3 Slave address
- 2.4 Register map
- 2.5 Flow chart
  - 2.5.1 Measurement of sensor signal (Continuous data output mode)
  - 2.5.2 Wake-up of MCU with INT function
- 2.6 Interrupt function
  - 2.6.1 Conditions setting
  - 2.6.2 Threshold value
  - 2.6.3 Times of exceeding threshold
  - 2.6.4 Threshold mode
  - 2.6.5 Window time
  - 2.6.6 Blind time

## 3. Demo Kit

- 3.1 Contents
- 3.2 Connection
- 3.3 Application interface

## 4. Notes / Precaution

- 4.1 Direction of the electrodes
- 4.2 Circuit example for the RF noise
- 4.3 Precautions for use

## 1. General Information

### 1.1 Introduction

The IRS-D200ST00R1 is extremely small digital PIR sensor with high performance (High S/N / reliability, good immunity to external disturbance).

The IRS-D200ST00R1 is SMD sensor that can be capable of reflow soldering while maintaining high S/N and it supports digital output. Since it is the world's smallest SMD PIR sensor, it can contribute to the flexibility of product design and can be adapted to the product design. The IRS-D200ST00R1 has a built-in pyroelectric element/pre-AMP/AD converter/digital signal processing.

Depending on the usage, It can be selected the usage mode from continuous data output and INT mode. If a PIR signal is required, a high-resolution PIR signal can be acquired through I<sup>2</sup>C. By using the INT signal, it is possible to use the MCU and other functions to sleep mode and trigger the MCU only when a person comes, greatly reducing the current consumption of the entire system.

### 1.2 Image of how to use

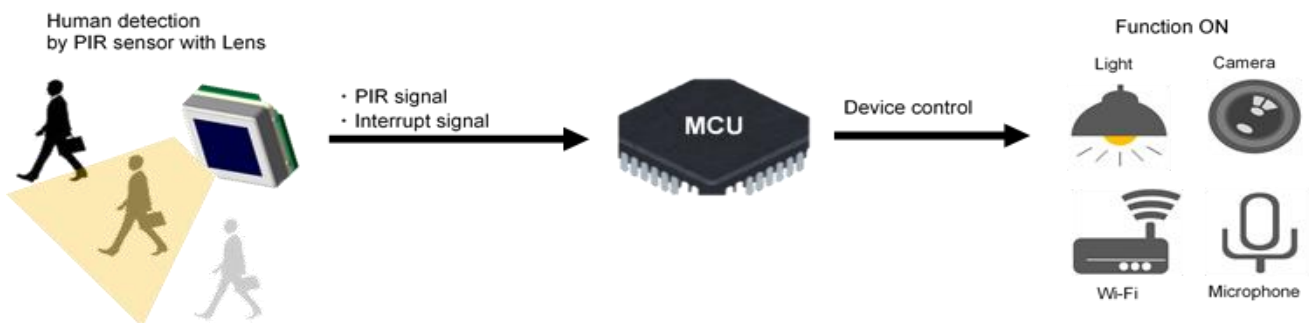

- Available to detect human
- Available to achieve low consumption of the system by the wake-up function.

### 1.3 Product figures / dimensions / spec.

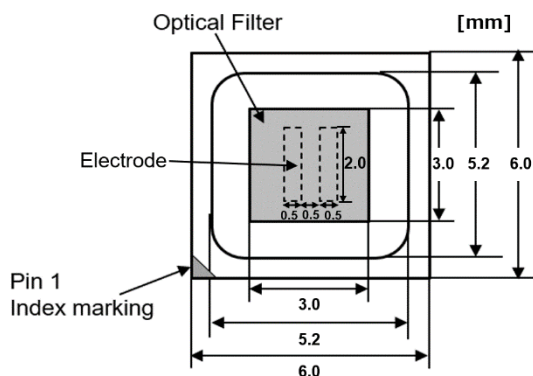

Power supply	1.8V – 3.3V
Package size	6.0 * 6.0 * 2.6 mm
FoV(Hor. / Ver.)	±55° / ±42°
Current consumption	Typ.8μA
Digital Interface	I2C / Interrupt signal
ADC	16bit
Operating Temperature	-25 – 85°C

# App.Note - SMD Digital PIR Sensor

## 1.4 Pin Configurations and Land pattern(TOP View)

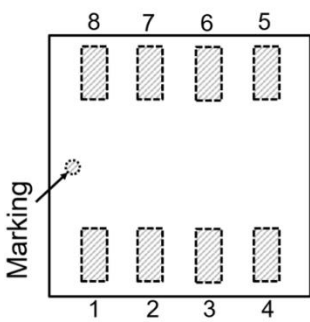

Fig. Pin Configurations

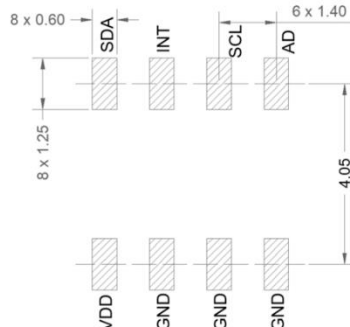

Fig. Land pattern

Pin No.	Symbol	Function
1	VDD	Power supply
2	TEST	Test pin
3	TEST	*Test pin should be connected to GND
4	GND	Ground
5	AD	Slave address
6	SCL	I <sup>2</sup> C Serial clock
7	INT	Interrupt output
8	SDA	I <sup>2</sup> C Data output

\*PIR output difer by the orientation of the electrode.

Please use at thcorrect electrode direction.(Refer to 3.1)

## 1.5 Circuit example

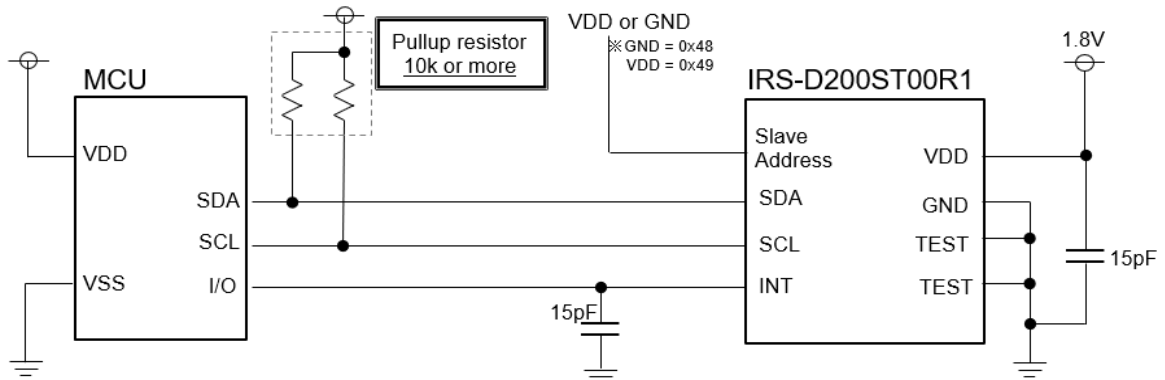

\*When using a pull-up resistance value less than 10kΩ, sensor noise could be large.

\*If it has RF effect to PIR sensor, please refer 3.2 Circuit example for the RF noise.

## 1.6 Reflow profile

- Recommended reflow profile : Please see the below figure
- Cycle of reflow : 2 times
- Recommendable composition of solder : Sn-3Ag-0.5Cu

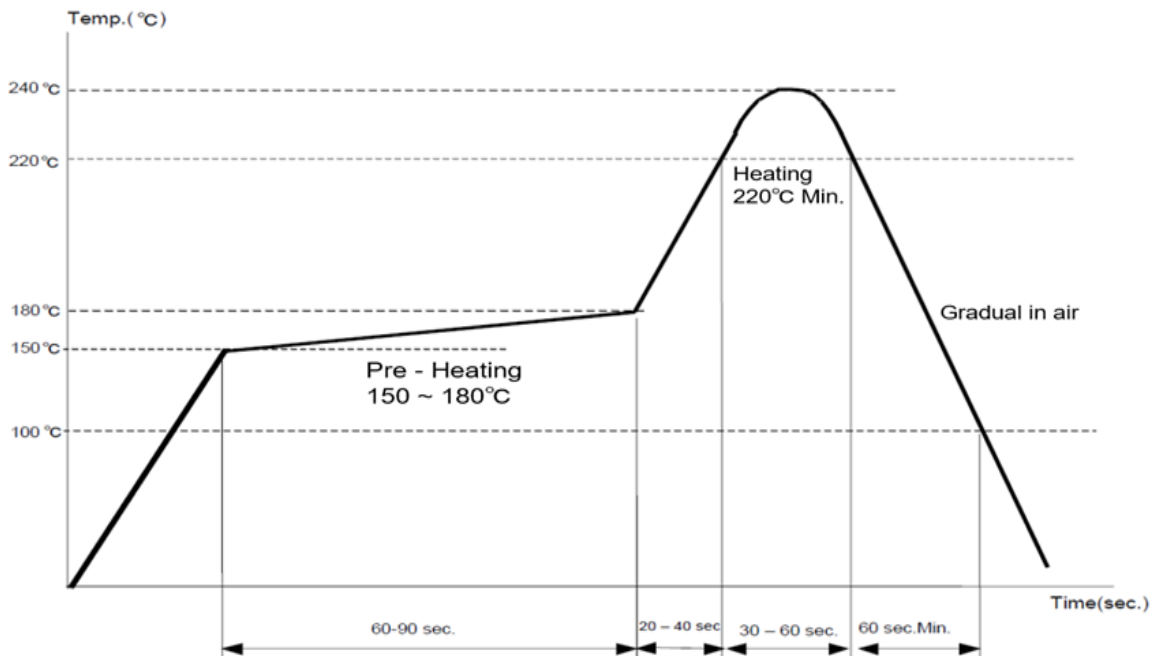

## 2. Data communication

### 2.1 I<sup>2</sup>C interface

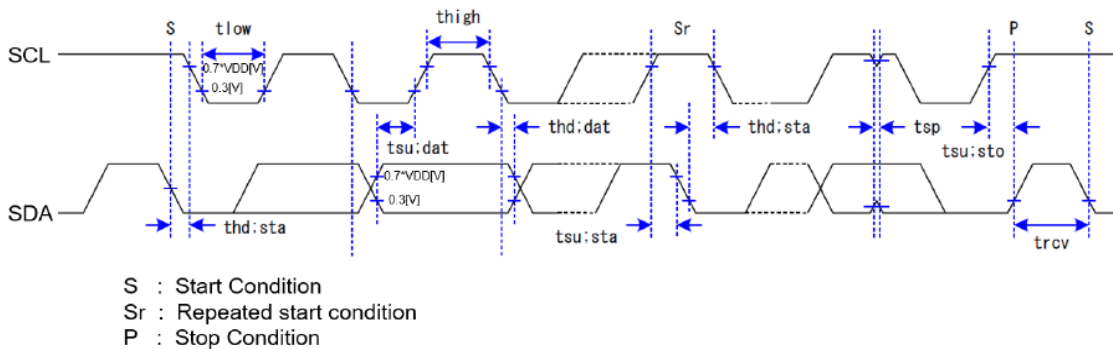

Parameter	Symbol	Standard Mode		Fast Mode		Unit
		Min.	Max.	Min.	Max.	
SCL frequency	f <sub>scl</sub>		100		400	kHz
SDA/SCL High level input voltage	V <sub>IH</sub>	0.7*VDD		0.7*VDD		V
SDA/SCL Low level input voltage	V <sub>IL</sub>		0.3		0.3	V
SCL Low period	t <sub>low</sub>	4.7		1.3		us
SCL High period	t <sub>high</sub>	4.0		0.6		us
Start condition hold time	t <sub>hd;sta</sub>	4.0		0.6		us
Stop condition set-up time	t <sub>su;sto</sub>	4.0		0.6		us
Start condition set-up time	t <sub>su;sta</sub>	4.7		0.6		us
Data set-up time	t <sub>su;dat</sub>	250		200		ns
Data hold time	t <sub>hd;dat</sub>	0		0		us
Rise time SDA,SCL	t <sub>r</sub>		1000		300	ns
Fall time SDA,SCL	t <sub>f</sub>		300		300	ns
Pulse width of spikes	t <sub>sp</sub>		50		50	ns
Bus free time between start-stop	t <sub>buf</sub>	1.3		1.3		us

\* SDA/SCL Low level input voltage should be  $\leq 0.3V$

### 2.2 I<sup>2</sup>C I/F functions

- |                            |               |
|----------------------------|---------------|
| ① Standard mode 100kbits/s | Available     |
| ② Fast mode 400kbits/s     | Available     |
| ③ 7bit slave address       | Available     |
| ④ Gneral call address      | Not available |
| ⑤ Bath clear               | Not available |

### 2.3 Slave address

IRS-D200ST00R1 has 2 slave address.

When the slave address pin is connected to GND : 0x48

When the slave address pin is connected to VDD : 0x49

## 2.4 Register map

Address	DATA							
	bit7	bit6	bit5	bit4	bit3	bit2	bit1	bit0
0x00								OP
0x01	Reserved, Do not modify							
0x02	DATA_BUFL[7:0]							
0x03	DATA_BUFH[7:0]							
0x04					STATUS[3:0]			
0x05	OVERCOUNT_UP[3:0]				OVERCOUNT_LO[3:0]			
0x06								SAMPLR
0x07							LPFR	HPFR
0x08	Reserved, Do not modify							
0x09					INTSEL[3:0]			
0x0A					THRESHCOUNT[2:0]			
0x0B	THRESH_HR[7:0]							
0x0C	THRESH_LR[7:0]							
0x0D	TIMER_LR[7:0]							
0x0E							TIMER_HR[1:0]	
0x0F to 0x19	Reserved, Do not modify							

Address	Name	Register	Remarks	Default
0x00	OP	[0]	"0" = Operation state, "1" = Sleep state	0
0x02	DATA_BUFL	[7:0]	The output signal of PIR. The data is refreshed when INTSEL="0001" (The refresh timing depends on SAMPLR)	0000 0000
0x03	DATA_BUFH	[7:0]		
0x04	STATUS	[3:0]	It can check the conditions of INT occurred.(Applied only the conditions set in INTSEL) "0001"= Continuous data output, "0010"= INT occurs when TIMER=0, "0100" or "1000" = INT occurs when meets the condition (Refer to 2.6.4)	0000
0x05	OVERCOUNT_UP	[3:0]	It can see the number of exceeding the threshold *The number is counted at upper & lower limits respectively *Overcount is applied only when INTSEL="0100" or "1000"	0000
0x05	OVERCOUNT_LO	[3:0]		0000
0x06	SAMPLR	[0]	ODR(Output data Rate) ; "0" = 50Hz, "1" = 100Hz	0
0x07	LPFR	[0]	LPF(Low pass filter) ; "0" = 10Hz, "1" = 7Hz	0
0x07	HPFR	[0]	HPF(High pass filter) ; "0" = 0.3Hz, "1" = 0.5Hz	0
0x09	INTSEL	[3:0]	Determine the conditions of INT occurrence "0001"= Continuous data output, "0010"= INT occurs when TIMER=0, "0100" or "1000" = INT occurs when meets the condition (Refer to 2.6.4)	0000
0x0A	THRESHCOUNT	[2:0]	Determine the counts of exceeding threshold to generate INT *Applied when INTSEL is set "0100" or "1000"	000
0x0B	THRESH_HR	[7:0]	Determine the upper & lower threshold (Threshold must be set by 8bit) *Applied when INTSEL is set "0100" or "1000"	0000 0000
0x0C	THRESH_LR	[7:0]		0000 0000
0x0D	TIMER_LR	[7:0]	Determine the period to count the number of exceeding threshold to generate INT *Applied when INTSEL is set "0100" or "1000"	0000 0000
0x0E	TIMER_HR	[1:0]		00

## 2.5 Flow chart example

### 2.5.1 Measurement of sensor signal (Continuous data output mode)

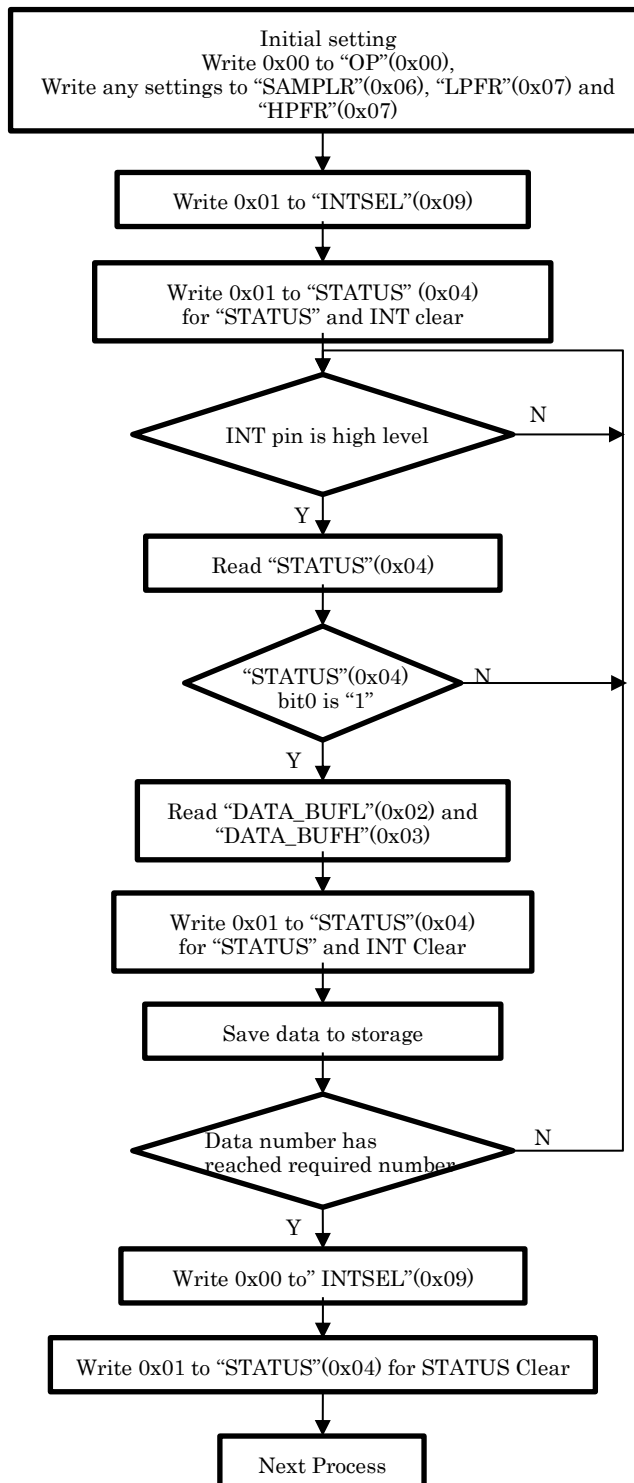

\* For an example of the source code, Please check the "INT signal.pdf". It is the source code when using "NUCLEO-L476RG". When you use another MCU, you need to change the source code to match the MCU.

## 2.5.2 Wake-up of MCU with INT function

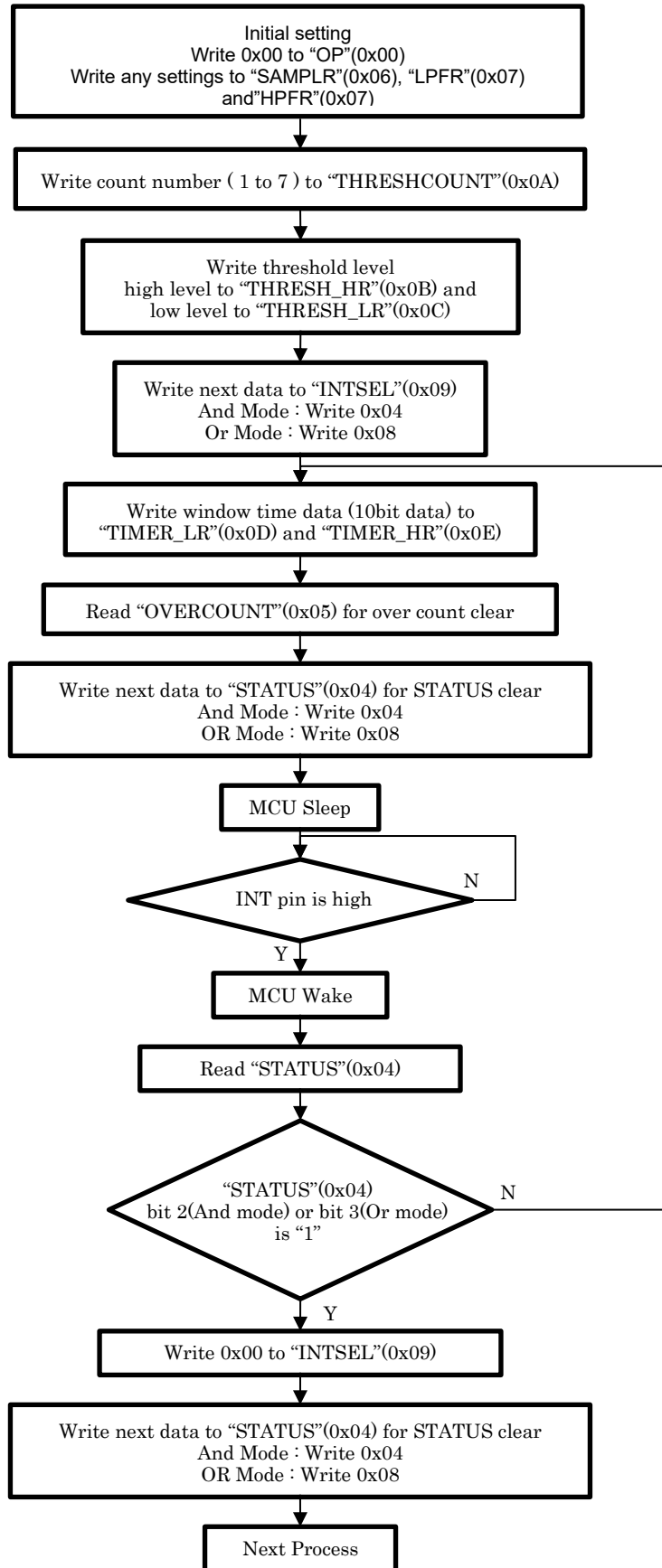

\* For an example of the source code, Please check the "INT signal.pdf". It is the source code when using "NUCLEO-L476RG".

When you use another MCU, you need to change the source code to match the MCU.

## 2.6 Interrupt function

### 2.6.1 Conditions settings

INT condition can be selected depending on the application. It can reduce the false detection.

Content	Spec	Register Address
Threshold Value	Upper threshold 8bits Lower threshold 8bits	Upper : 0x0B Lower : 0x0C
Times of exceeding threshold	1 – 7 times	0x0A
Threshold mode	Upper side OR Lower side Upper side AND Lower side	0x09
Window Time	Max.10.23sec(ODR:100Hz) Max. 20.46sec(ODR:50Hz)	0x0D, 0x0E

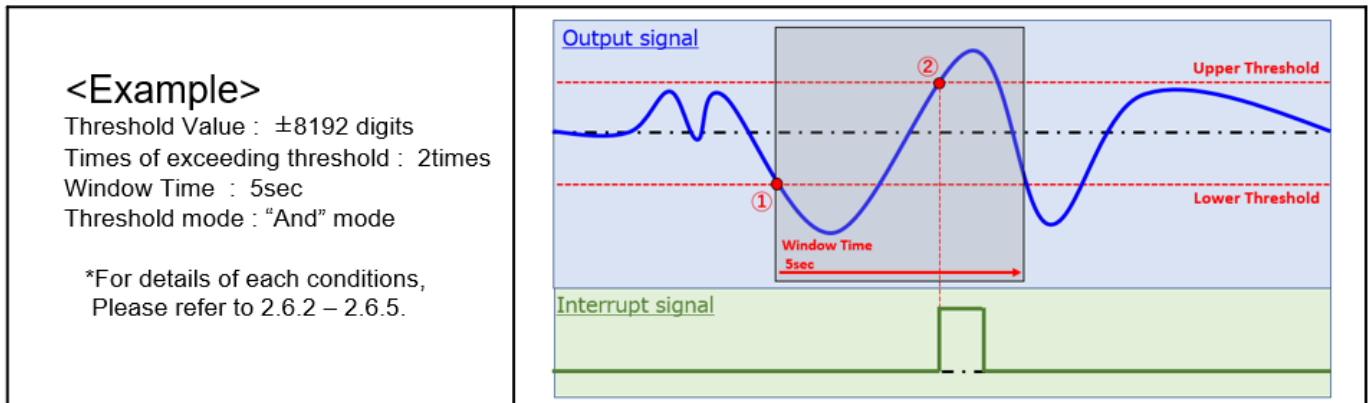

### 2.6.2 Threshold value

The threshold value can be set in the "Upper threshold" and "Lower threshold".

Binary	Decimal	Upper Threshold Value[digits]	Lower Threshold value[digits]
0000 0000	0	0	0
0000 0001	1	128	-128
0000 0010	2	256	-256
⋮	⋮	⋮	⋮
1111 1110	254	32512	-32512
1111 1111	255	32640	-32640

**<Example>**

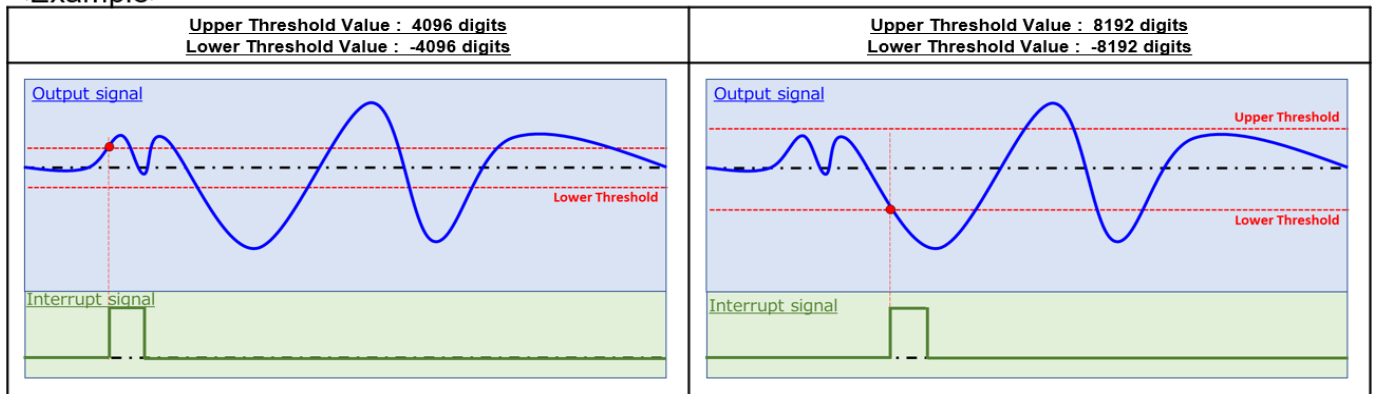

## 2.6.3 Times of exceeding threshold

Binary	Decimal	Number of times the threshold exceeded
000	0	-
001	1	1 time
010	2	2 times
011	3	3 times
100	4	4 times
101	5	5 times
110	6	6 times
111	7	7 times

If the “Times of exceeding threshold” is more than 2 times, it is needed to set the “Window Time.(Refer 2.6.5)

<Example>

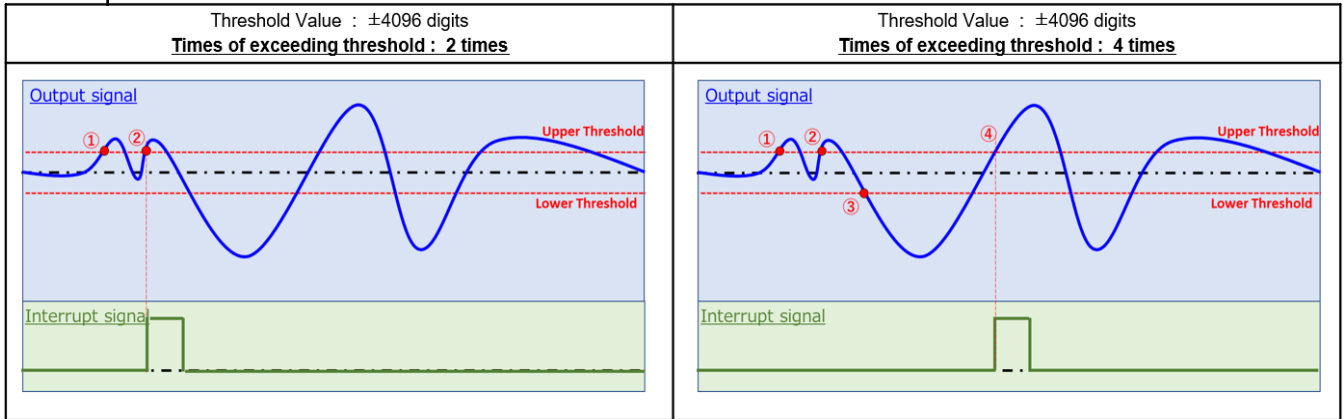

## 2.6.4 Threshold mode

■ **And mode** : Write b0100 to Register Address “0x09”.

To generate the interrupt signal when the total number of times the upper and lower threshold value have been exceeded the number of times set in a register address “0x0A”.

And, If only the upper threshold exceeds the number of times, Interrupt does not have.

■ **Or mode** : Write b1000 to Register Address “0x09”.

To generate the interrupt signal when the total number of times the upper and lower threshold value have been exceeded the number of times set in a register address “0x0A”.

<Example>

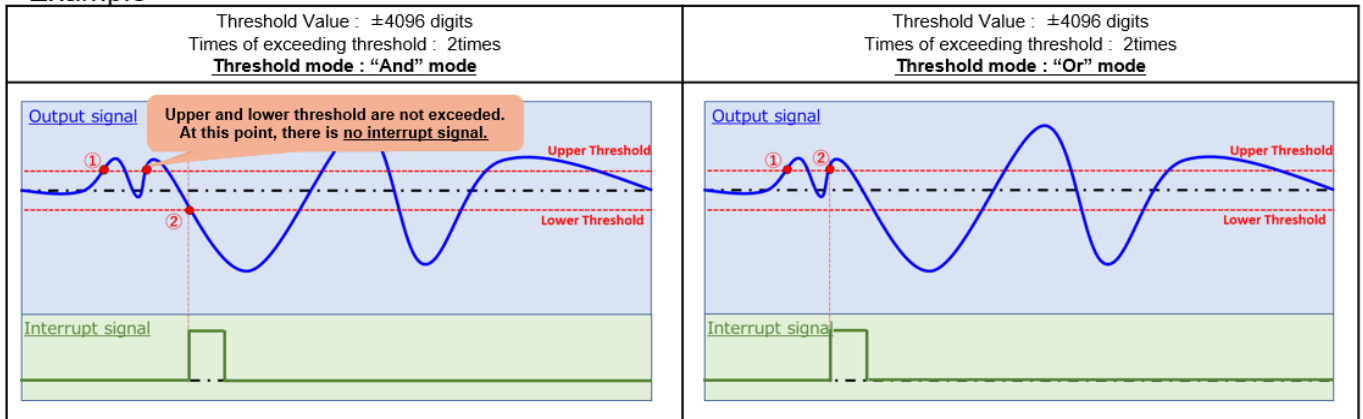

## 2.6.5 Window time

“Window Time” is the time trigger condition for the interrupt.

Binary		Decimal	Window Time [s]	
TIMER_HR(0x0E)	TIMER_LR(0x0D)		ODR = 50Hz	ODR = 100Hz
00	0000 0000	0	0	0
00	0000 0001	1	0.02	0.01
00	0000 0010	2	0.04	0.02
⋮	⋮	⋮	⋮	⋮
00	1111 1111	255	5.10	2.55
01	0000 0000	256	5.12	2.56
⋮	⋮	⋮	⋮	⋮
11	1111 1111	1023	20.46	10.23

### <Example>

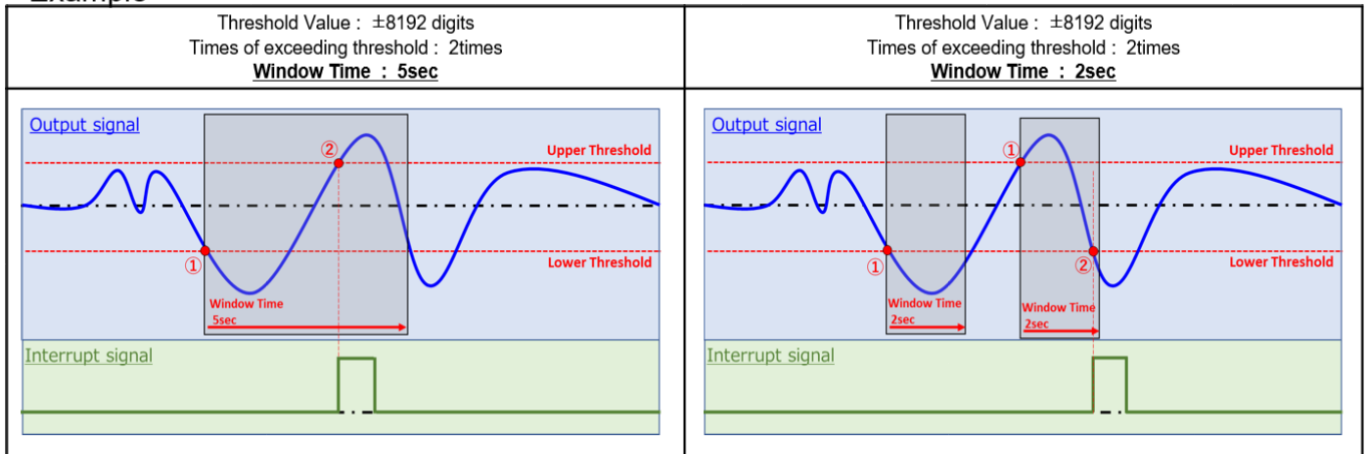

## 2.6.6 Blind time

When it does not need Interrupt signal from IRS-D200ST00R1.

By writing "0x00" to "INTSEL"(0x09), It can stop it.

The flowing chart is reference.("Threshold mode" of this chart is "or mode")

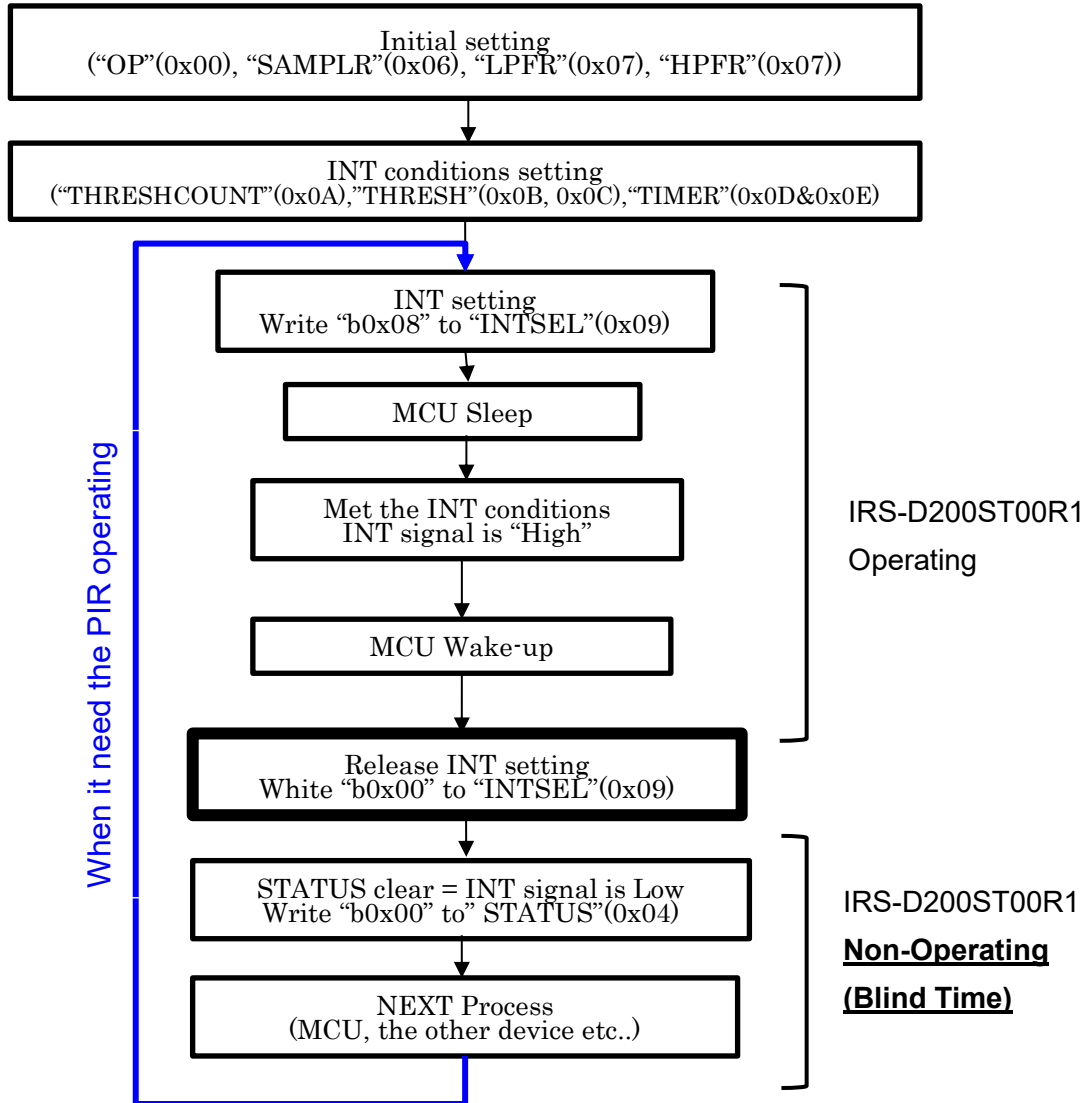

### 3. Demo Kit

#### 3.1 Enclosed parts

- ① Sensor Board
- ② MCU Board
- ③ Cable (Sensor ~ MCU)
- ④ USB cable (MCU ~ PC)
- ⑤ Lens (E650, E654, E669)

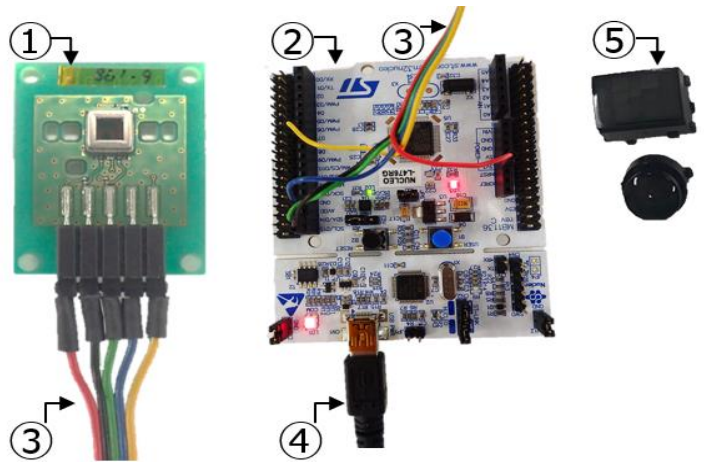

#### 3.2 Connection

##### 3.2.1 Sensor board

To connect sensor board to MCU board, 5

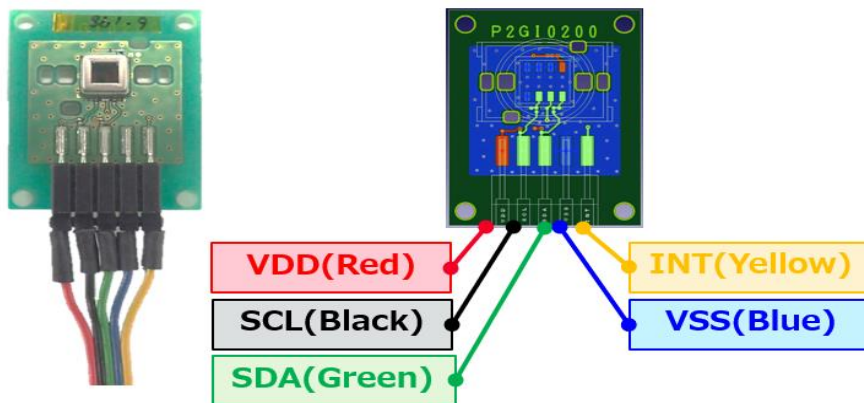

##### 3.2.2 MCU board

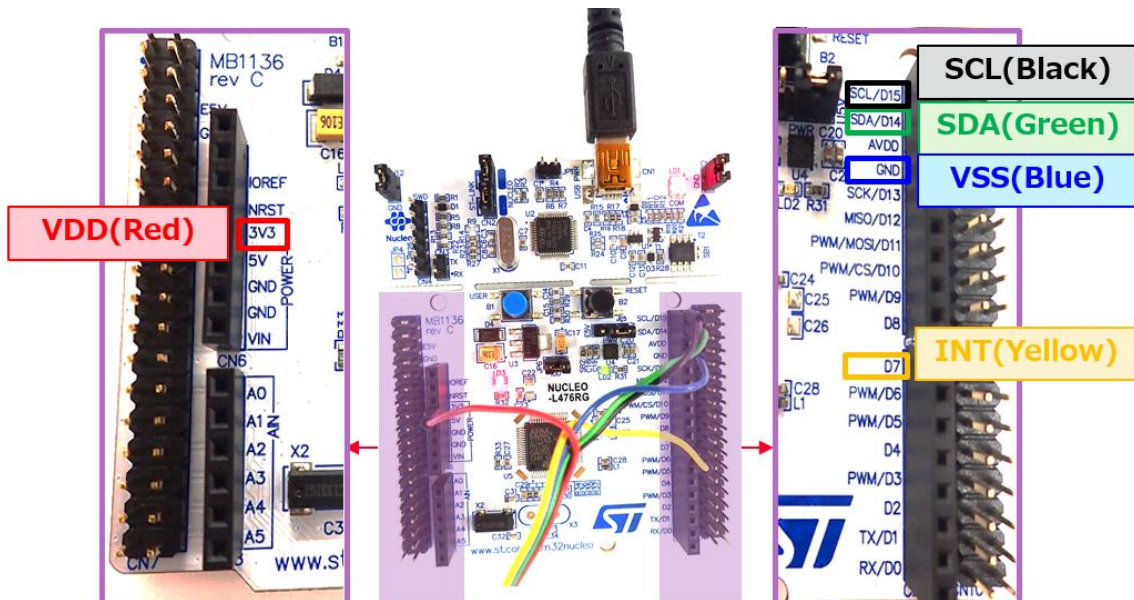

## 3.3 Demo application Interface

### 3.3.1 Preperation for operating a demo kit

- ① To select "ST Microelectronics ST Link Virtual COM Port" from COM Port List.
- ② To press the "Connect" button and confirm that "Status" is "Connect".
- ③ To press "Start" button, the output of Sensor and INT is displayed ("Start" changes to "Stop")
- ④ To press "Stop" button, the output of Sensor and INT is stopped.

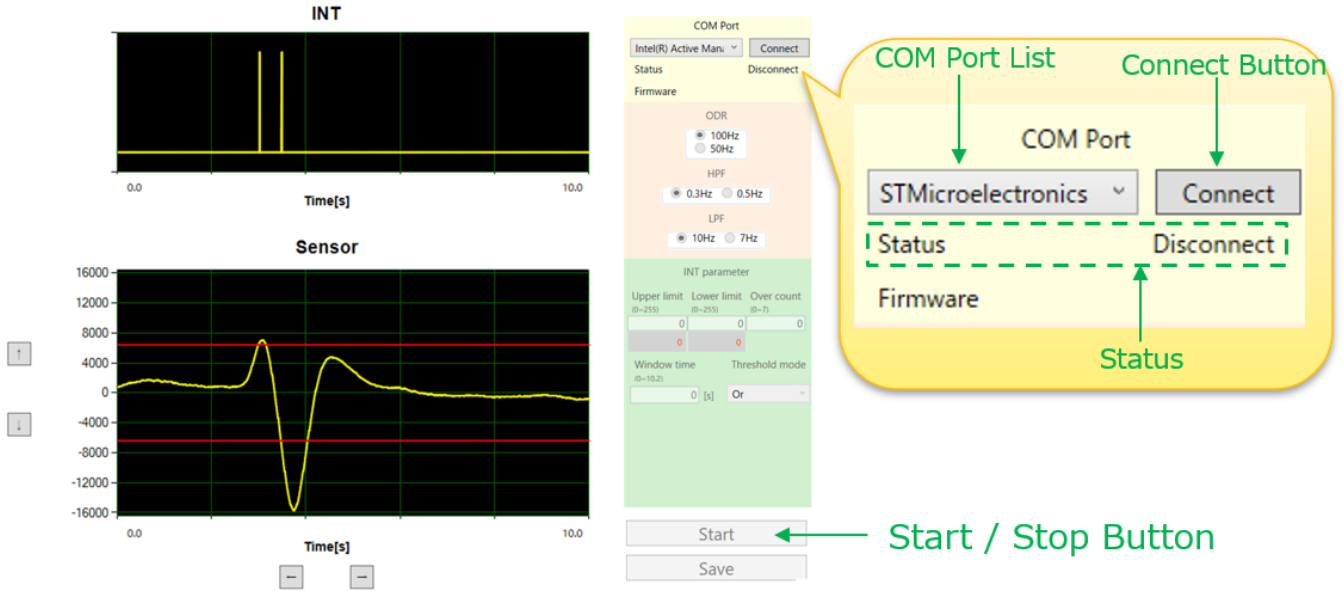

### 3.3.2 Interface function 1

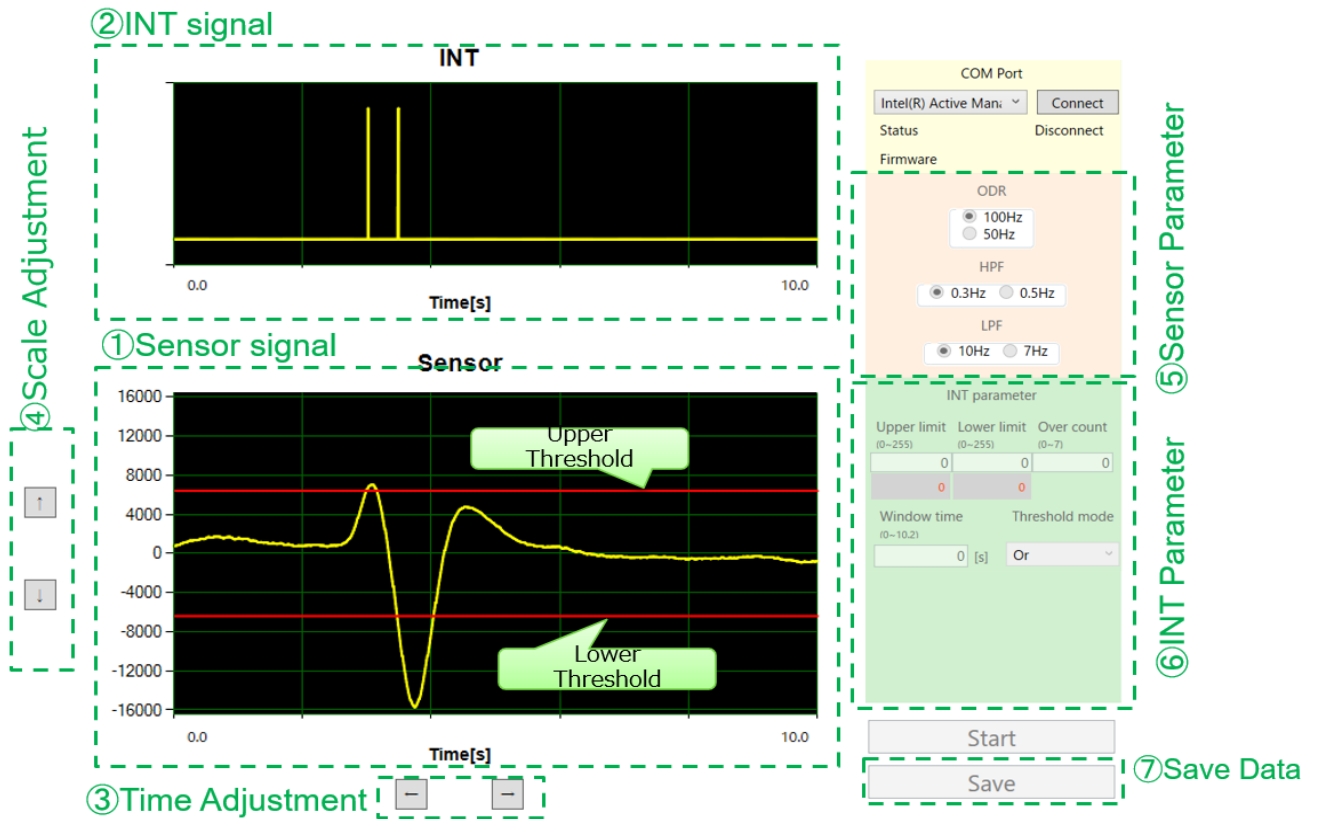

# App.Note - SMD Digital PIR Sensor

## 3.3.3 Interface function 2

④ Sensor output scale change

② INT signal

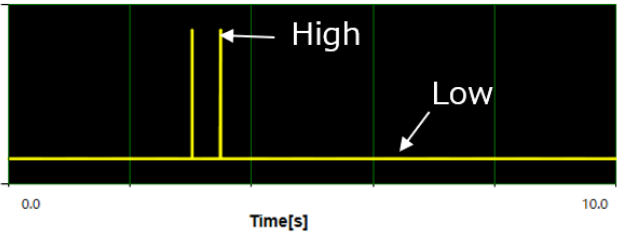

① Sensor signal

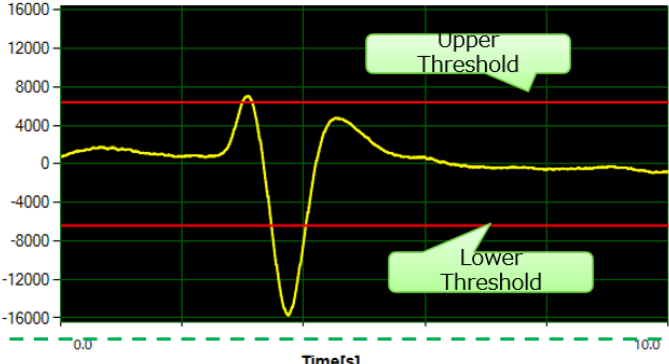

③ Time scale change

① Sensor signal  
You can check the sensor output.  
You can display the threshold by clicking the screen.

② INT signal  
You can check the Interrupt output.  
When meet the Interrupt condition,  
INT output is "High" signal.

③ Time scale change  
You can select the 4 condition.  
(10s, 20s, 30s, 60s)  
"→" button to scale up.  
"←" button to scale down.

④ Sensor output scale change  
You can select the 4 condition.  
(±4000, ±8000, ±16000, ±32000)  
"↑" button to scale up.  
"↓" button to scale down.

X axis : Time[s]  
Y axis : Sensor output[digits]

## 3.3.4 Interface function 3

⑤ Sensor Parameter

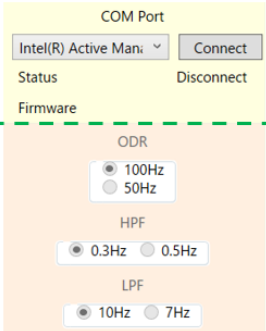

⑥ INT Condition

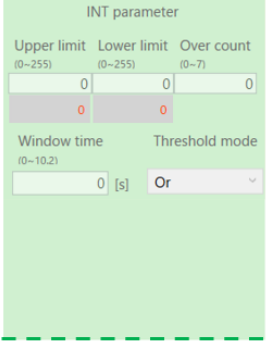

⑤ Sensor Parameter  
You can select the sensor output parameter.

- ODR(Output Data Rate)  
You can select the Sensor signal sampling frequency.  
To select from "100Hz" and "50Hz".
- HPF(High Pass Filter)  
HPF cutoff frequency can be selected from "0.3Hz" and "0.5Hz".
- LPF(Low Pass Filter)  
LPF cutoff frequency can be selected from "7Hz" and "10Hz".

⑥ INT(Interrupt) Parameter  
You can change the INT condition.  
INT condition has "Upper limit", "Lower limit", "Over count", "Window time" and Threshold mode.

- Upper Limit / Lower Limit  
You can select the threshold. It divides 32768digits into 256.  
It can set the upper and lower limits separately.  
And you can see the value of threshold by gray part.

Upper limit (0~255)	Lower limit (0~255)
50	50
6400	-6400

← Select threshold(0~255)  
← Value of threshold

- Over Count  
You can select the number of times the threshold is exceeded  
from 1 to 7 times.

Start

Save

<https://www.murata.com>

Copyright © Murata Manufacturing Co., Ltd. All Rights Reserved.

14 / 17

## 3.3.5 Interface function 4

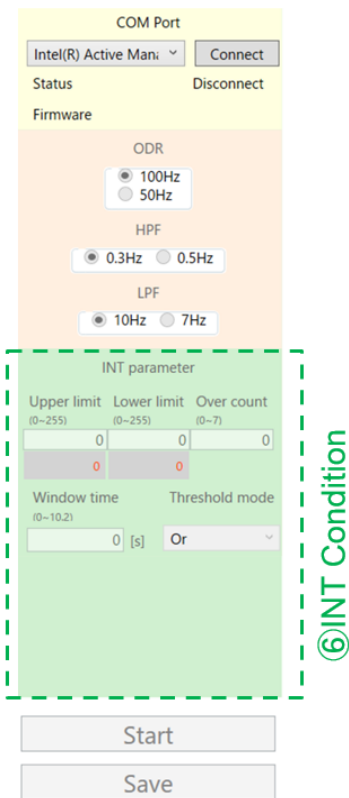

### ⑥INT(Interrupt) Parameter

#### - Window Time

You can select from while 0.0 ~ 10.2[s].

INT become "High", when the Over Count number is reached within Window Time.

<Example : Over Count = 3 times>

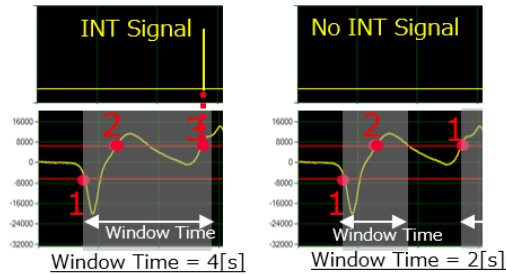

#### - Threshold mode

You can select the "Or mode" and "And mode".

<Example : Over Count = 2 times>

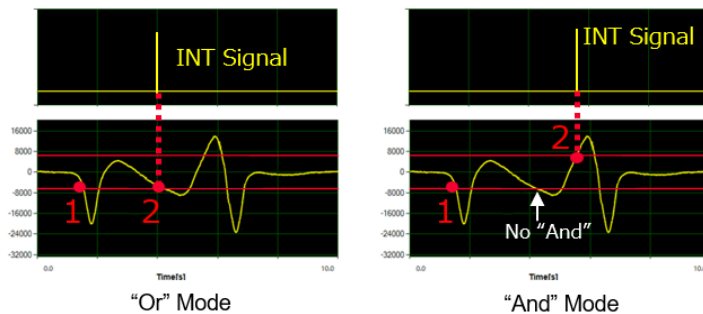

## 3.3.6 Interface function 5

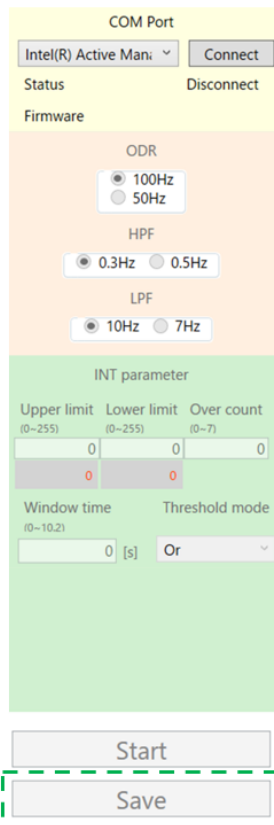

### ⑦Save Data

1. Stop the waveform by "Stop" Button
2. Press the "Save" Button
3. File save dialog is displayed

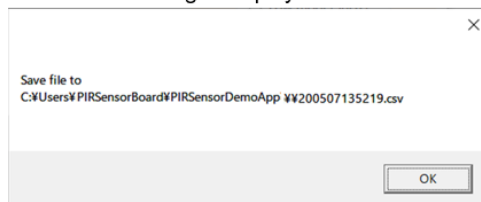

4. Waveform data have the same folder of "PIRSensorBoard.exe"

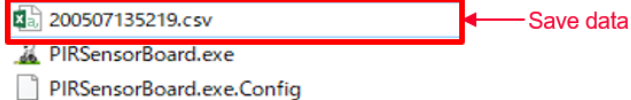

5. Save file has "Time[ms]", "INT output" and "Sensor output"

※CSV file name

It is saved date.

200629103730

Year Month Day Time

## 4. Notes / Precaution

### 4.1 Direction of the electrodes

Please be sure to keep the electrodes direction to avoid signal output cancelation.

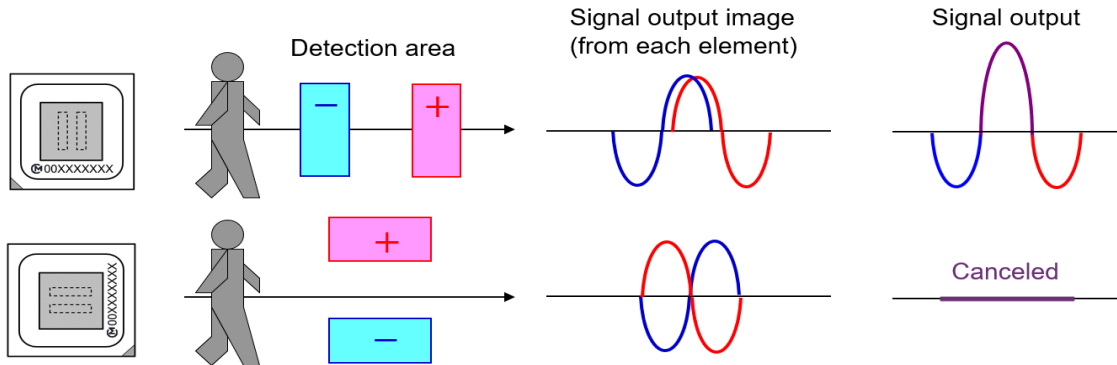

### 4.2 Circuit example for the RF noise

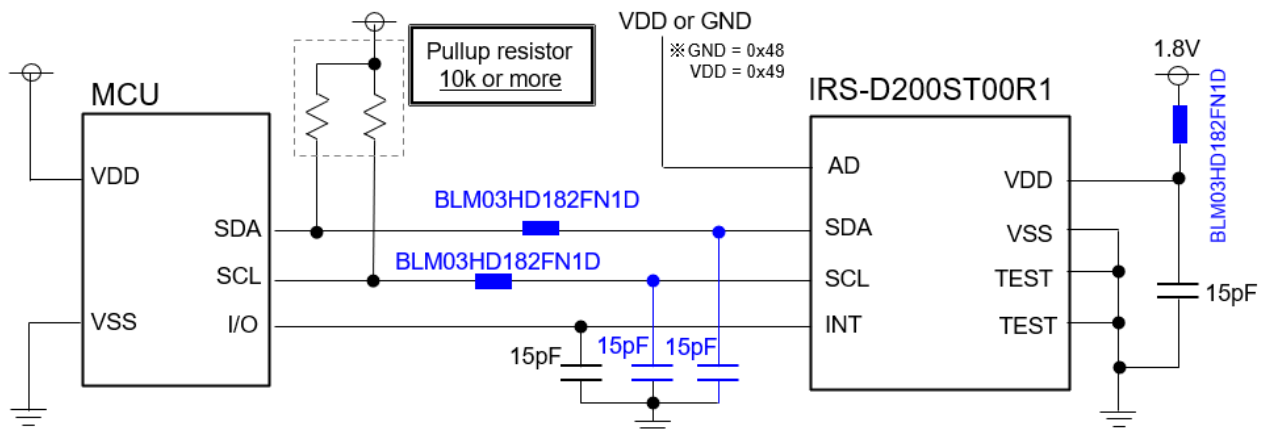

\*If it has RF effects to PIR sensor, it can be avoided by ferrite bead, capacitor and other EMI components.

### 4.3 Precautions for use

- 1) Please make sure that your product has been evaluated in view of your specifications with our product being mounted to your product.
- 2) In the case of outdoor use, suitable optical filter and water / humidity proof structure should be applied.
- 3) Please use a stabilized power supply to prevent failure or malfunction.
- 4) Please avoid using the pyroelectric infrared sensor in the following conditions to prevent failure or malfunction.
  - a) In such a fluid as water, alcohol etc. corrosive gas(SO<sub>2</sub>,Cl<sub>2</sub>,NO<sub>x</sub> etc.) or sea breeze.
  - b) In high humidity
  - c) In a place exposed directly to sunlight or headlight of automobile.
  - d) In a place exposed to rapid ambient temperature change.
  - e) In a place exposed directly to blow from air-conditioner or heater.
  - f) In a place exposed to strong vibration.

## App.Note - SMD Digital PIR Sensor

---

- g) In a place exposed to strong electromagnetic field.
- h) In a place where there are obstacles (glass,walls,etc.) which are infrared ray cannot pass through in detection area of the pyroelectric infrared sensor.
- i) In a place where electrification and static electricity are generated.
- j) In any other similar places mentioned above a) ~ i).

### 5) Note for PCB design

- a) Avoid placing heatgenerating components near to the pyroelectric infrared sensor.
  - Pyroelectric infrared sensor may react to heat change and generate output signal.
- b) Avoid placing RF components near to the pyroelectric infrared sensor.
  - Antenna, RF transmitter and module.
- c) The wiring pattern should be wide and short to avoid false detection due to RF noise.
- d) Design with sufficiently enhanced ground plane.